

Sauna Laadi 3

weka

Art.-Nr.: 191.0104.00.00
191.0104.00.0X

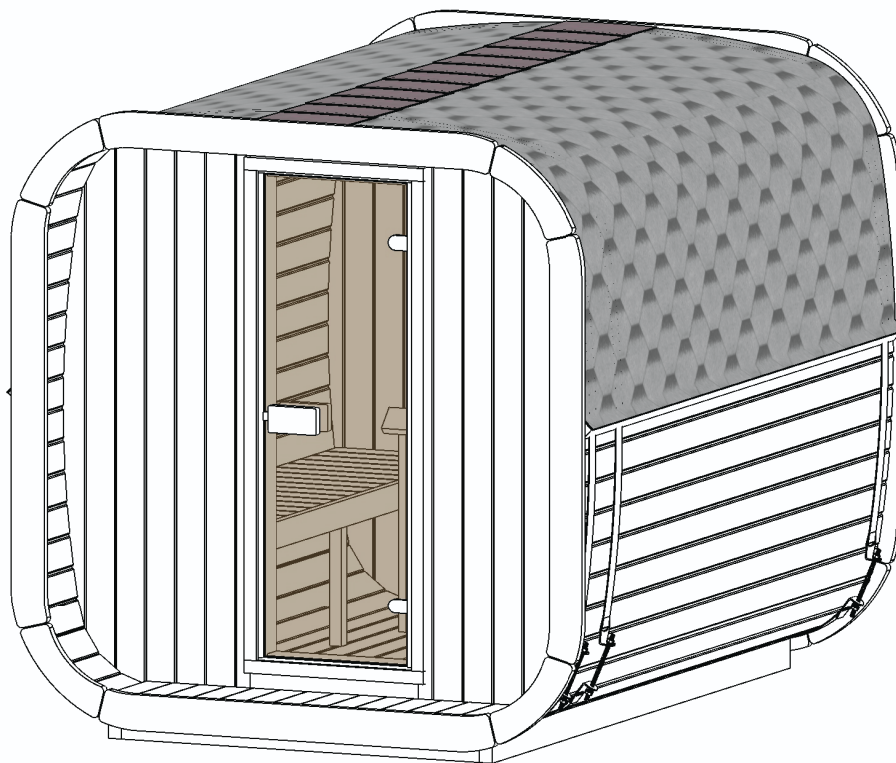

Montageanleitung

www.weka-holzbau.com



weka Holzbau GmbH
Postfach 20 02 04
D-17013 Neubrandenburg



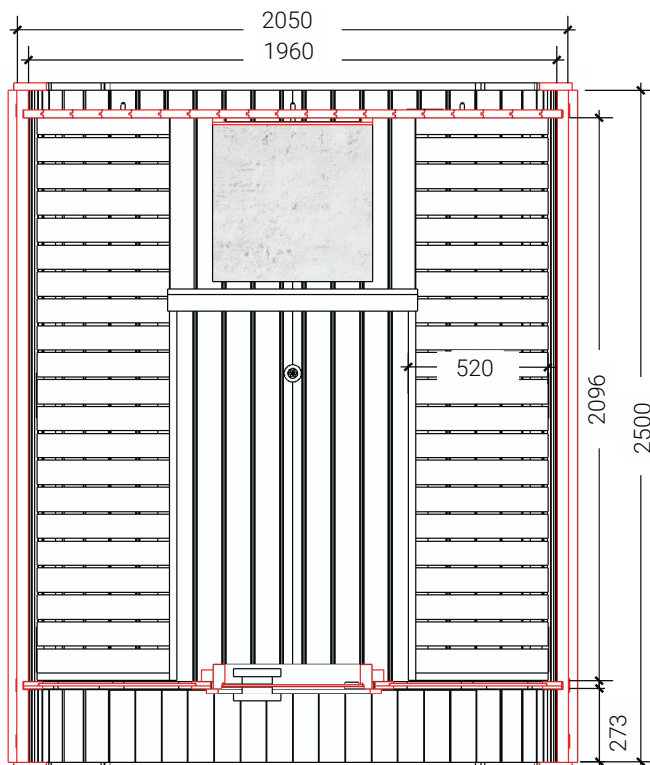
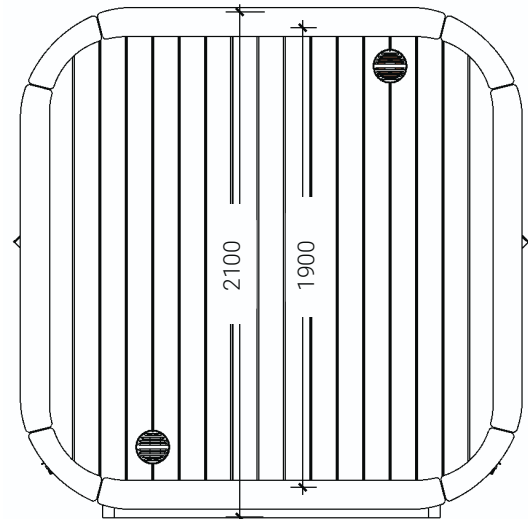
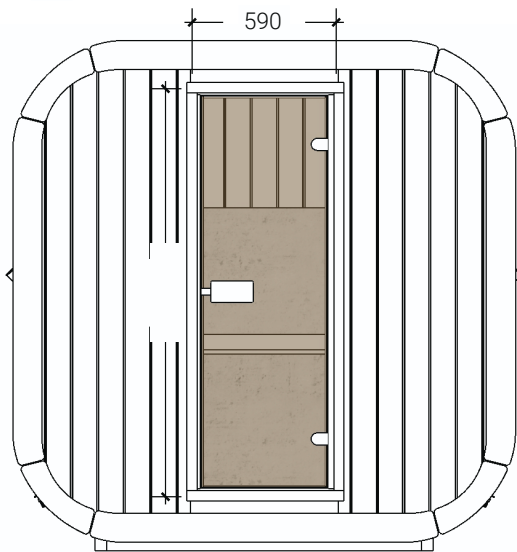
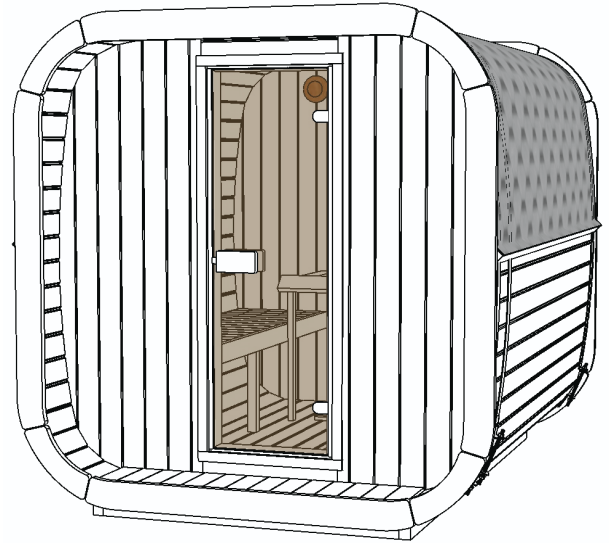
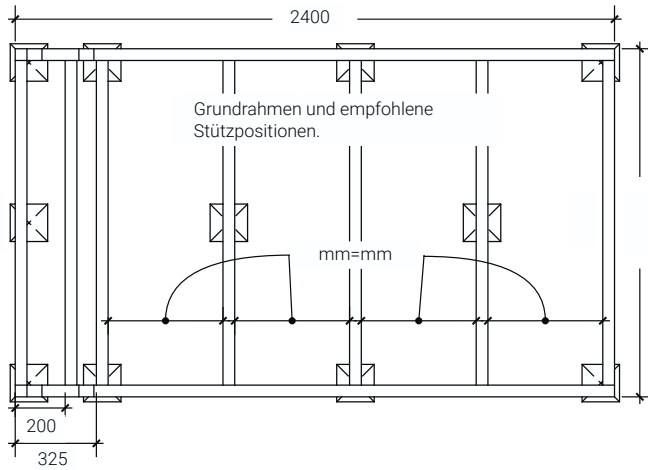

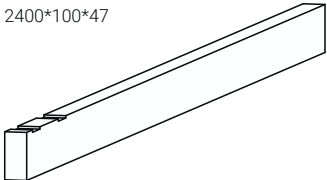
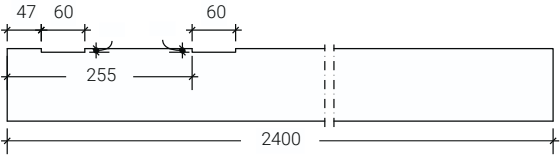
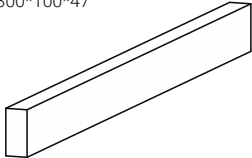
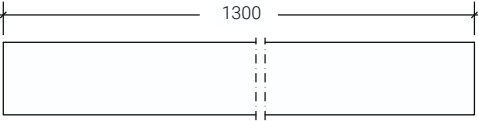
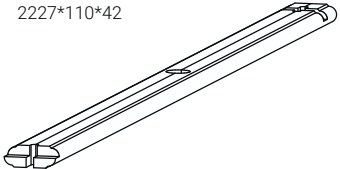
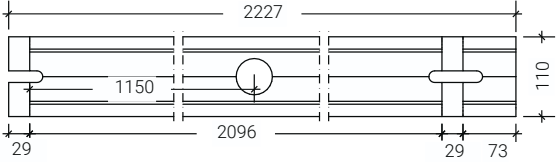
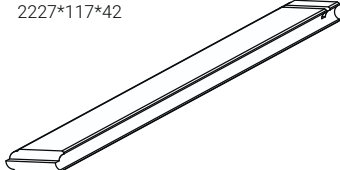
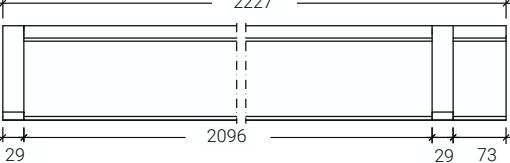
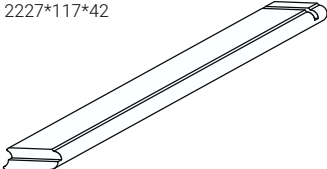
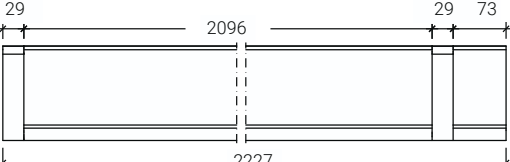
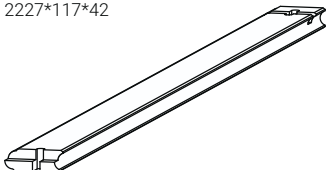
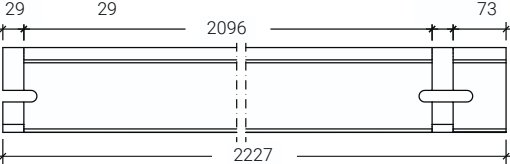
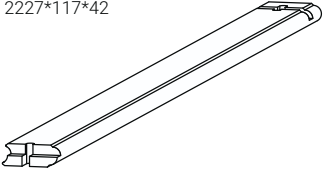
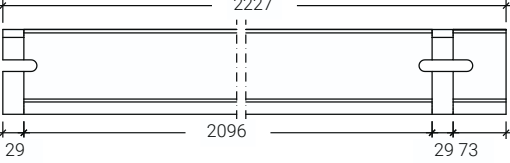
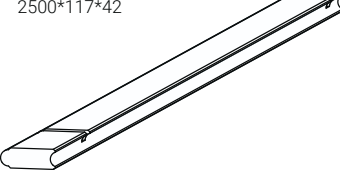
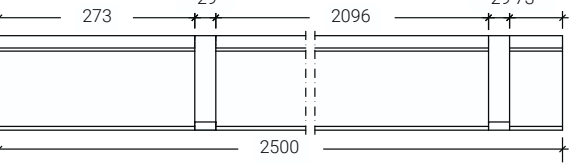
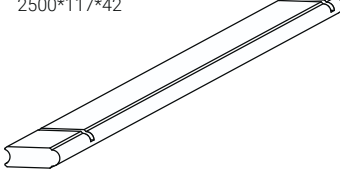
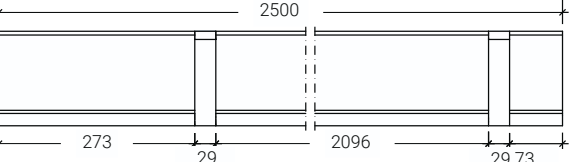
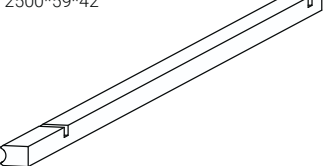
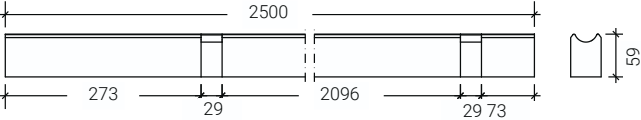
Sie erreichen uns:
Mo - Fr 08:30 - 18:00 Uhr
+49 (0)395/42908-0

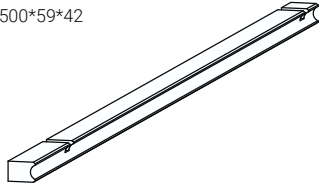
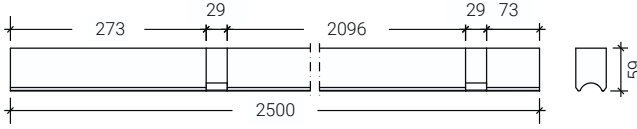
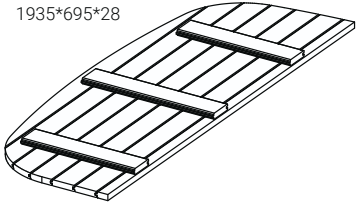
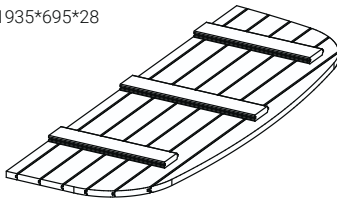
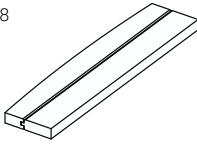
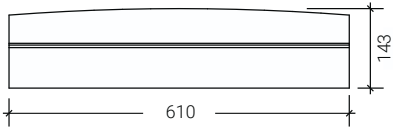
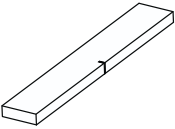
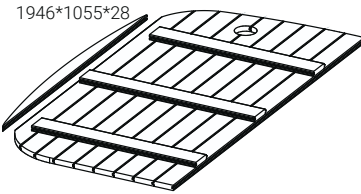
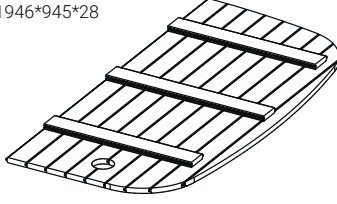
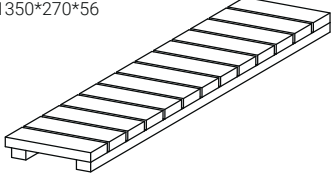
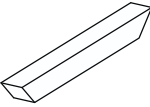
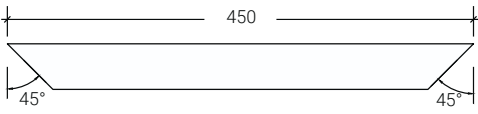



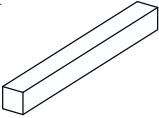
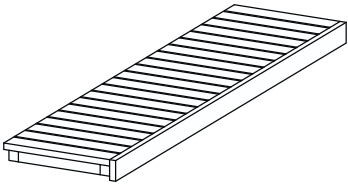
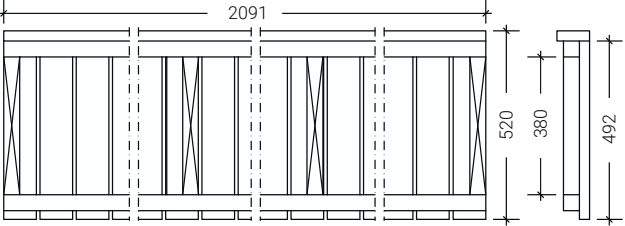
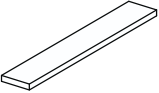
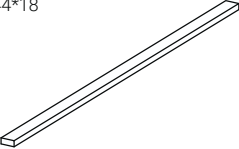
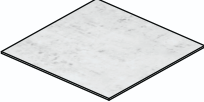

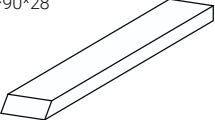
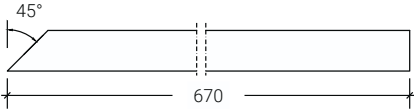

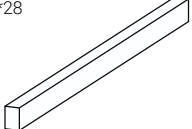
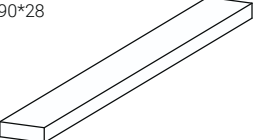
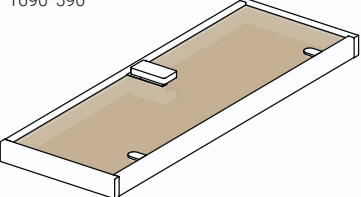
Sauna Laadi 3 250,Ø200

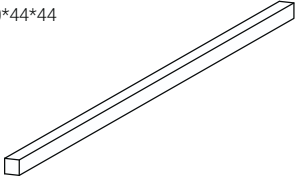
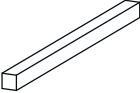
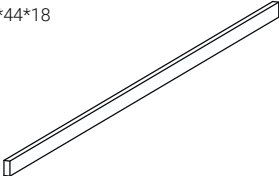
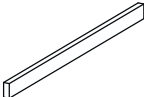
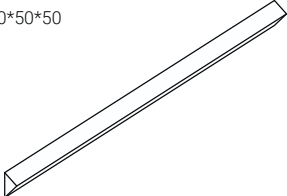

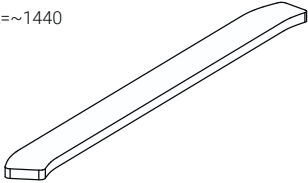

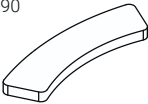

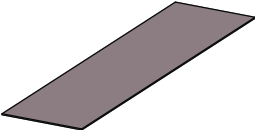

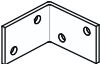
<p>DET 1</p> <p>Art.-Nr. KSM100/2400X</p>	<p>x2</p>	<p>2400*100*47</p> 	
<p>DET 2</p> <p>Art.-Nr. KSM100/1300</p>	<p>x7</p>	<p>1300*100*47</p> 	
<p>DET 3</p> <p>Art.-Nr. 2-TSTL110/2227</p>	<p>x1</p>	<p>2227*110*42</p> 	
<p>DET 3b</p> <p>Art.-Nr. TSTL117/2227XV</p>	<p>x5</p>	<p>2227*117*42</p> 	
<p>DET 3a</p> <p>Art.-Nr. TSTL117/2227XP</p>	<p>x5</p>	<p>2227*117*42</p> 	
<p>DET 3b/H</p> <p>Art.-Nr. TSTL117/2227XV-01</p>	<p>x1</p>	<p>2227*117*42</p> 	
<p>DET 3a/H</p> <p>Art.-Nr. KSM100/2400X</p>	<p>x1</p>	<p>2227*117*42</p> 	
<p>DET 3D</p> <p>Art.-Nr. TSTL117/2500XV</p>	<p>x28</p>	<p>2500*117*42</p> 	
<p>DET 3c</p> <p>Art.-Nr. TSTL117/2500XP</p>	<p>x27</p>	<p>2500*117*42</p> 	
<p>DET 6a DET 3-Gegenstück</p> <p>Art.-Nr. TSTL59/2500XLP</p>	<p>x1</p>	<p>2500*59*42</p> 	

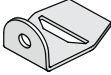
<p>DET 6b DET 3-Gegenstück Art.-Nr. TSTL59/2500XLV</p>	<p>x1</p>	<p>2500*59*42</p> 	
<p>DET Sb Art.-Nr. 2-TIC20PE/28V</p>	<p>x1</p>	<p>1935*695*28</p> 	
<p>DET Sa Art.-Nr. 2-TIC20PE/28P</p>	<p>x1</p>	<p>1935*695*28</p> 	
<p>DET Ta Art.-Nr. 2-KSL28/143/610</p>	<p>x1</p>	<p>610*143*28</p> 	
<p>DET Tb Art.-Nr. KTL94/610X</p>	<p>x1</p>	<p>610*94*28</p> 	
<p>DET Y1 Art.-Nr. 2-TIC20PT/28V</p>	<p>x1</p>	<p>1946*1055*28</p> 	
<p>DET Y2 Art.-Nr. KSM100/2400X</p>	<p>x1</p>	<p>1946*945*28</p> 	
<p>DET 4 Art.-Nr. 2-TTE270/1350</p>	<p>x1</p>	<p>1350*270*56</p> 	
<p>DET 10a Art.-Nr. TSTL117/2500XP</p>	<p>x4</p>	<p>450*44*44</p> 	
<p>DET 10c Art.-Nr. KHP44/170</p>	<p>x2</p>	<p>170*44*44</p> 	

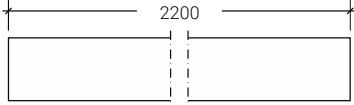
<p>DET 10b</p> <p>Art.-Nr. KHP44/430</p>	<p>x2</p>	<p>430*44*44</p> 	
<p>DET 10</p> <p>Art.-Nr. 2-TLA520/2091</p>	<p>x2</p>	<p>2091*520*72</p> 	
<p>DET 20</p> <p>Art.-Nr. THL94/595</p>	<p>x5</p>	<p>595*94*18</p> 	
<p>DET L</p> <p>Art.-Nr. KHL44/1200</p>	<p>x2</p>	<p>1200*44*18</p> 	
<p>DET 20a</p> <p>Art.-Nr. MIN595/595-HAL</p>	<p>x1</p>	<p>595*595*8</p> 	
<p>DET 20b</p> <p>Art.-Nr. MIN1250/595-HAL</p>	<p>x1</p>	<p>1250*595*8</p> 	
<p>DET 15a</p> <p>Art.-Nr. TLAV90/670XP</p>	<p>x2</p>	<p>670*90*28</p> 	
<p>DET 15b</p> <p>Art.-Nr. TLAV42/90</p>	<p>x2</p>	<p>90*42*28</p> 	
<p>DET 15c</p> <p>Art.-Nr. TLAV42/700</p>	<p>x2</p>	<p>700*42*28</p> 	
<p>DET 15d</p> <p>Art.-Nr. TLAV90/930</p>	<p>x1</p>	<p>930*90*28</p> 	
<p>DET 21</p> <p>Art.-Nr. D590/1690PR8</p>	<p>x1</p>	<p>1690*590</p> 	

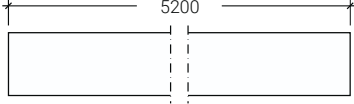
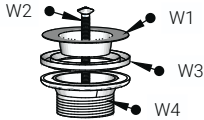
<p>DET 21c</p> <p>Art.-Nr. KHP44/1690</p>	<p>x2</p>	<p>1690*44*44</p> 	
<p>DET 21d</p> <p>Art.-Nr. KHP44/680</p>	<p>x2</p>	<p>680*44*44</p> 	
<p>DET 21a</p> <p>Art.-Nr. KHL44/1660</p>	<p>x2</p>	<p>1660*44*18</p> 	
<p>DET 21b</p> <p>Art.-Nr. KHL44/650</p>	<p>x2</p>	<p>650*44*18</p> 	
<p>DET 22</p> <p>Art.-Nr. TSTL50/2500X</p>	<p>x2</p>	<p>2500*50*50</p> 	
<p>DET 25a</p> <p>Art.-Nr. TSTL50/2500X</p>	<p>x8</p>	<p>L≈1440</p> 	
<p>DET 25b</p> <p>Art.-Nr. OL-IC20-02</p>	<p>x8</p>	<p>L≈390</p> 	
<p>Dachbahn</p> <p>Art.-Nr. KATAL</p>	<p>11 m</p>		
<p>DET N</p> <p>Art.-Nr. KAT-HAR</p>	<p>x9</p>		
<p>DET O</p> <p>Art.-Nr. KAT-SIN</p>	<p>x69</p>		
<p>DET V</p> <p>Art.-Nr. KI-VIN-25/40/40-ZN</p>	<p>x4</p>	<p>40*40*25</p> 	

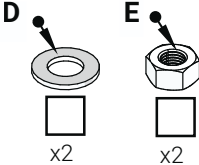
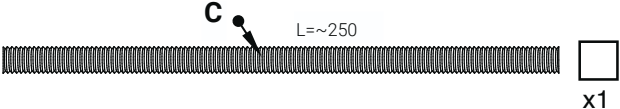
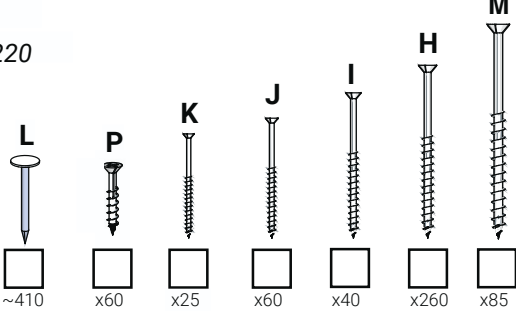
<p>DET B</p> <p>Art.-Nr. VITSKL-RV</p>	<p>x12</p>		
<p>DET A1</p> <p>Art.-Nr. VITS/2200</p>	<p>x3</p>		
<p>DET A2</p> <p>Art.-Nr. VITS/5200</p>	<p>x3</p>		
<p>DET W</p> <p>Art.-Nr. TRAPP</p>	<p>x1 km /l</p>		
<p>DET G</p> <p>Art.-Nr. MU-VENT-PU</p>	<p>x1</p>		
<p>DET F</p> <p>Art.-Nr. MU-VENT-ZN</p>	<p>x3</p>		
<p>Art.-Nr. KI-KERL-12-RV1</p>	<p>x6</p>	 <p>D x2 E x2</p>	<p>Art.-Nr. KI-ICO-160-220</p>
 <p>C L ≈ 250 x1</p>		 <p>L ~410 P x60 K x25 J x60 I x40 H x260 M x85</p>	

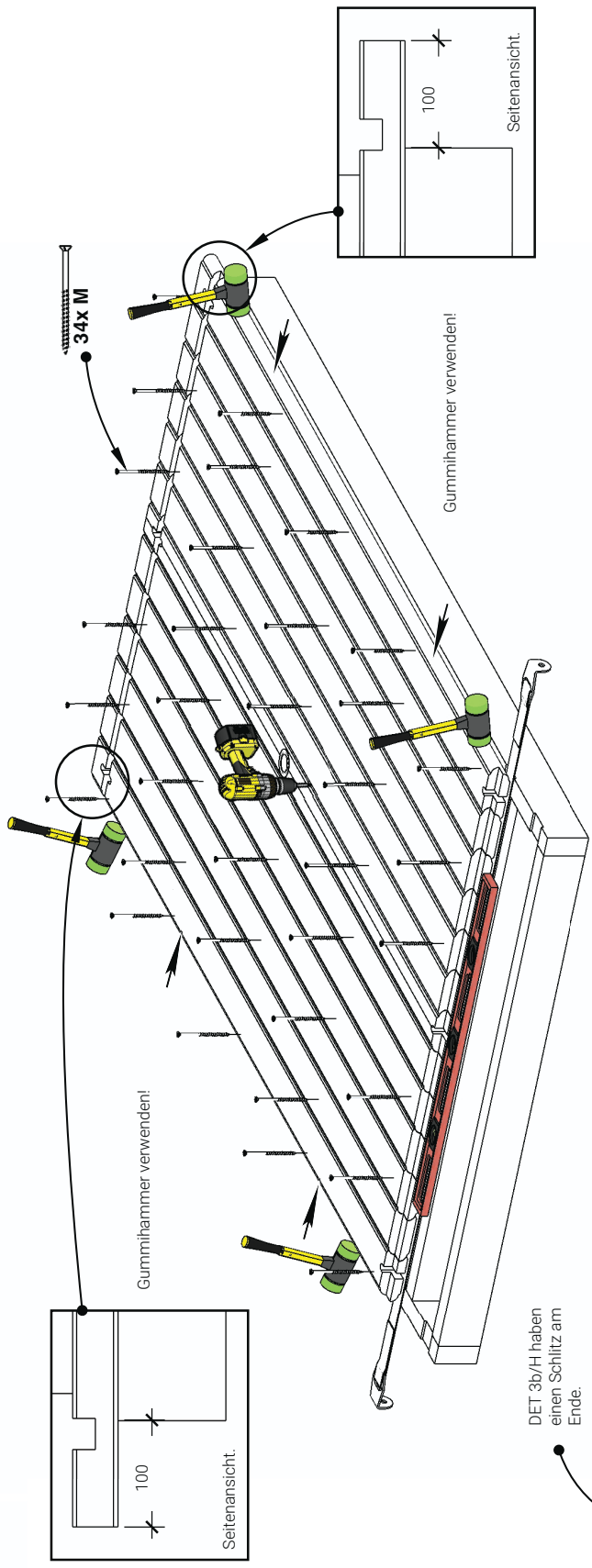

DET 3b/H haben einen Schlitz am Ende.

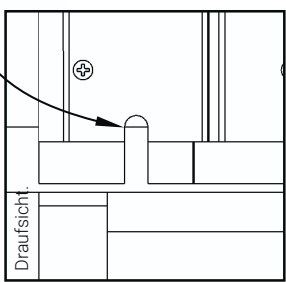

Befestigen Sie die Schrauben über einem Brett, diagonal in jedem Brett.

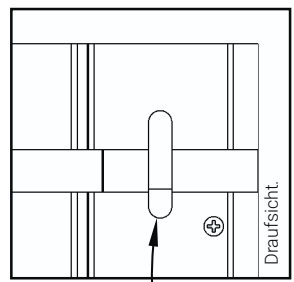
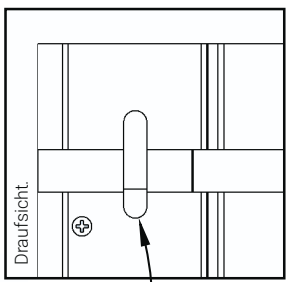
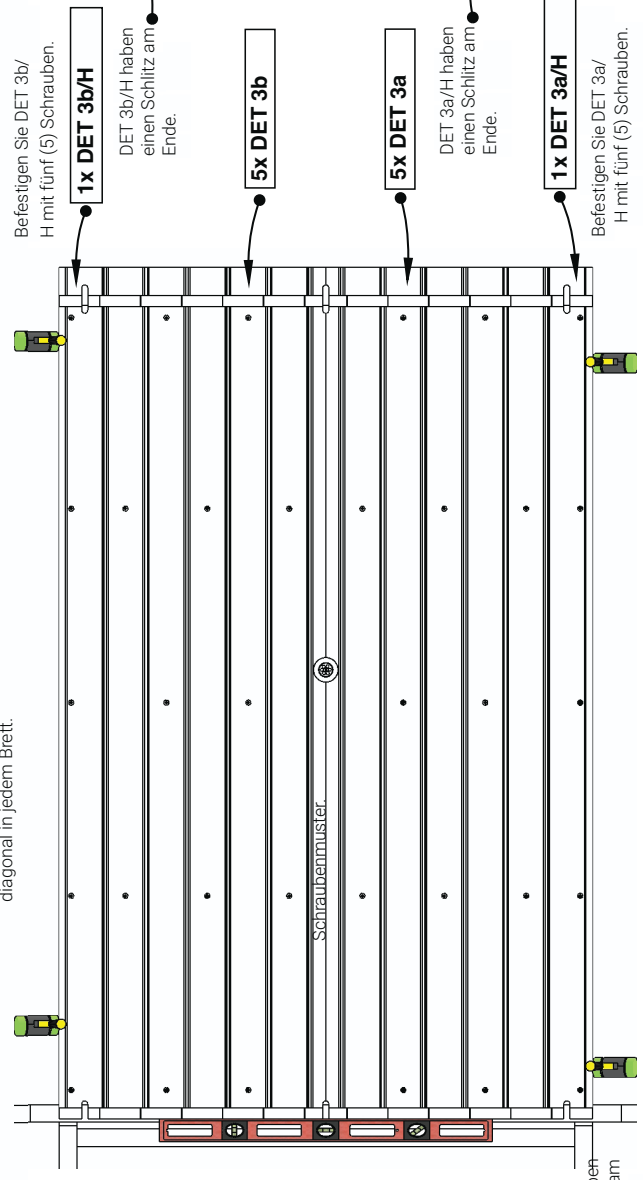

DET 3a/H haben einen Schlitz am Ende.

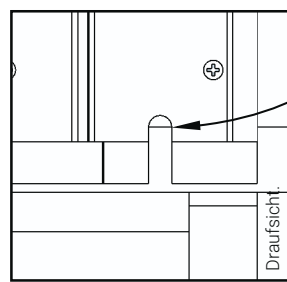

Holzvorderwandmontage

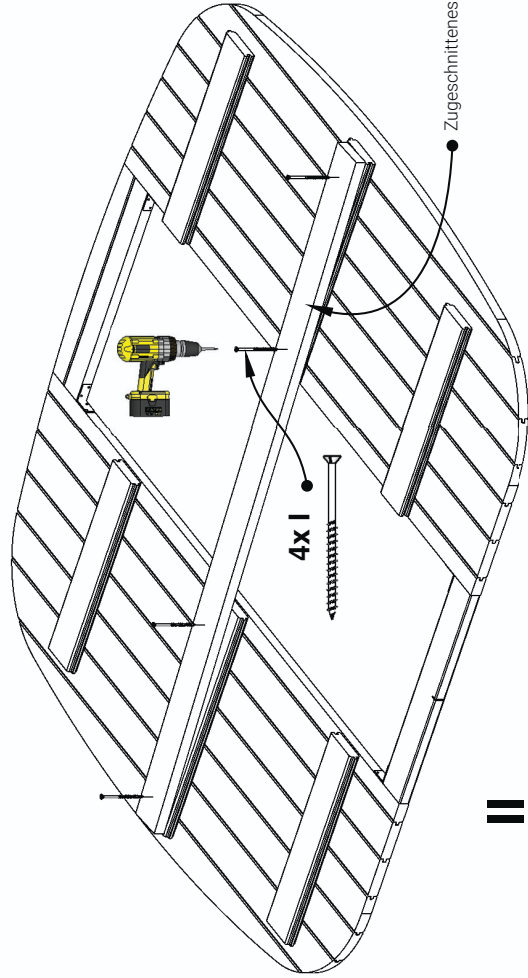
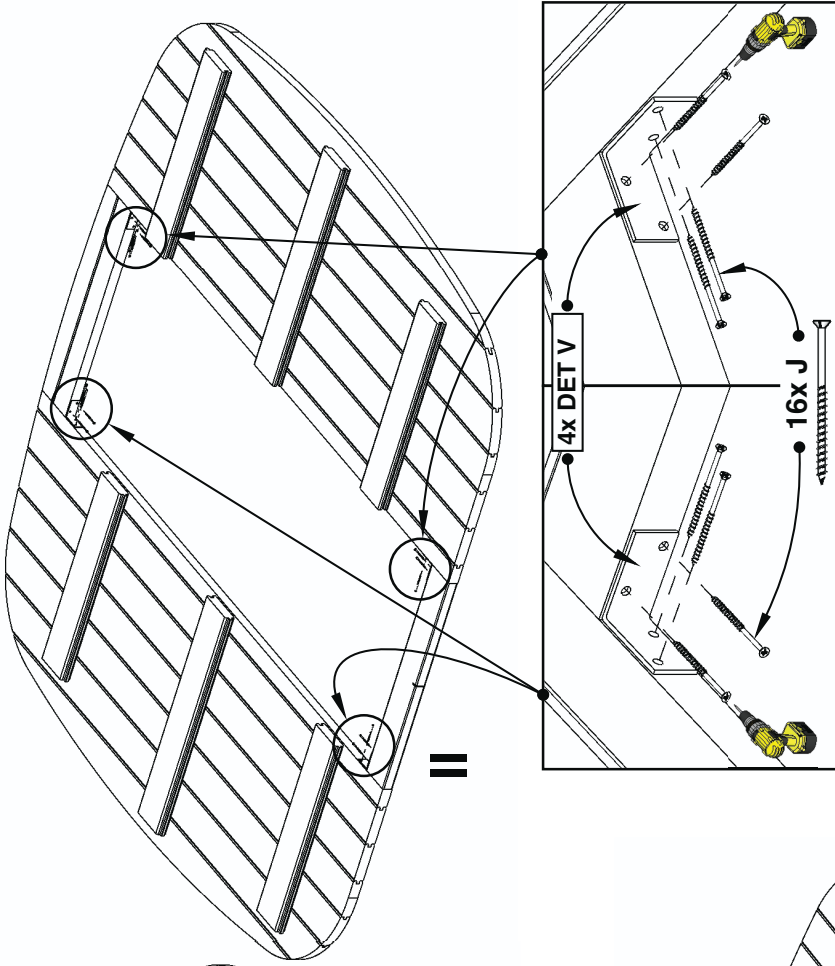
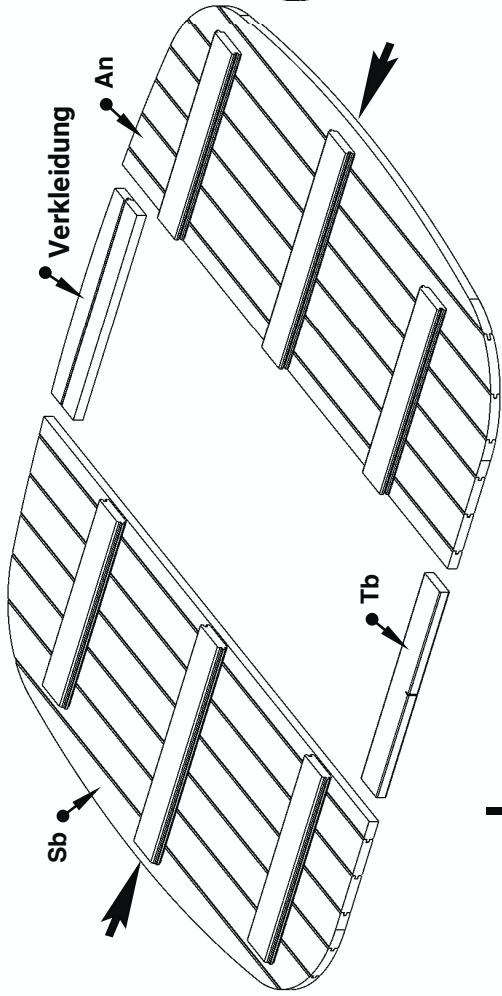

Holzrückwandmontage

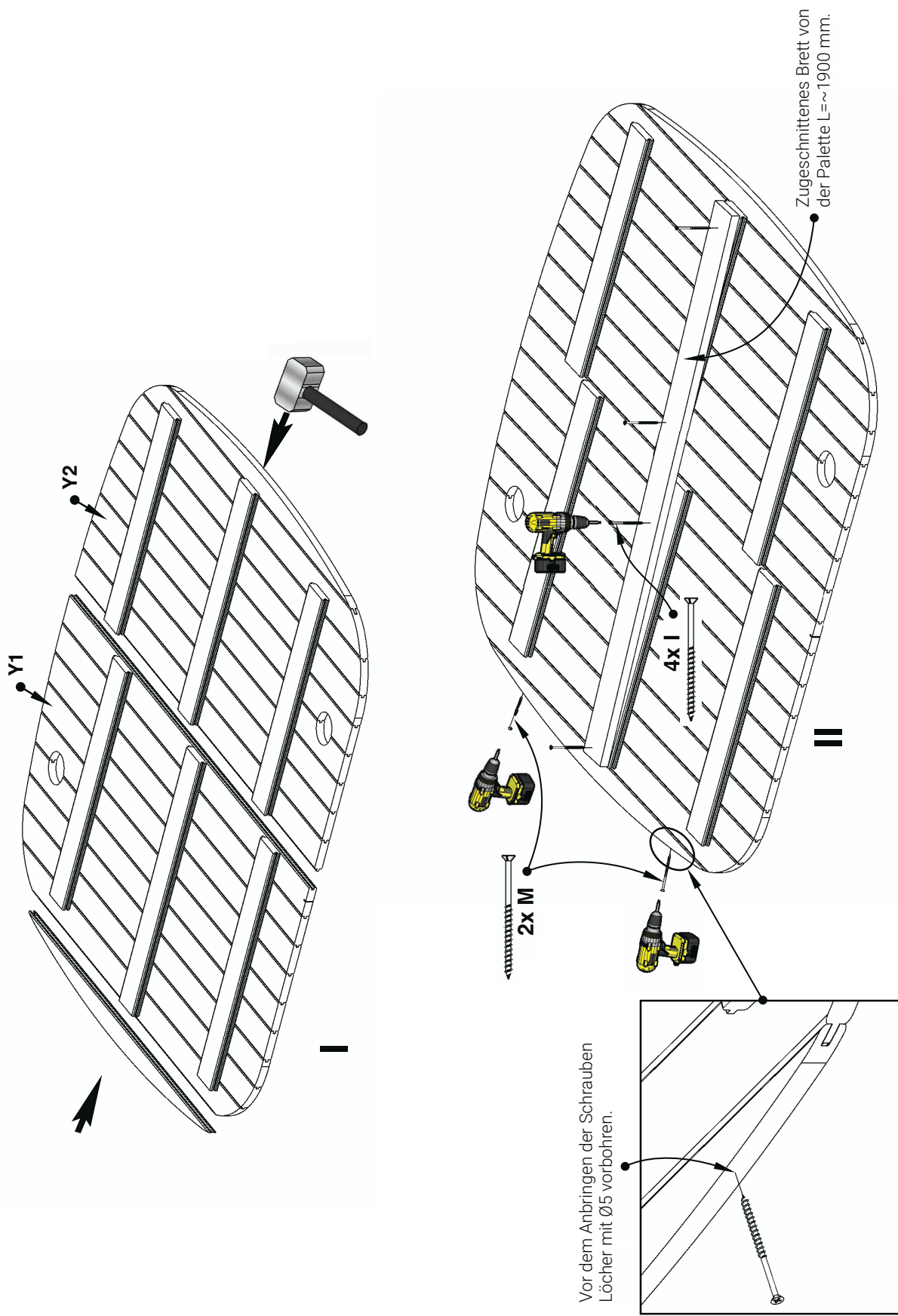

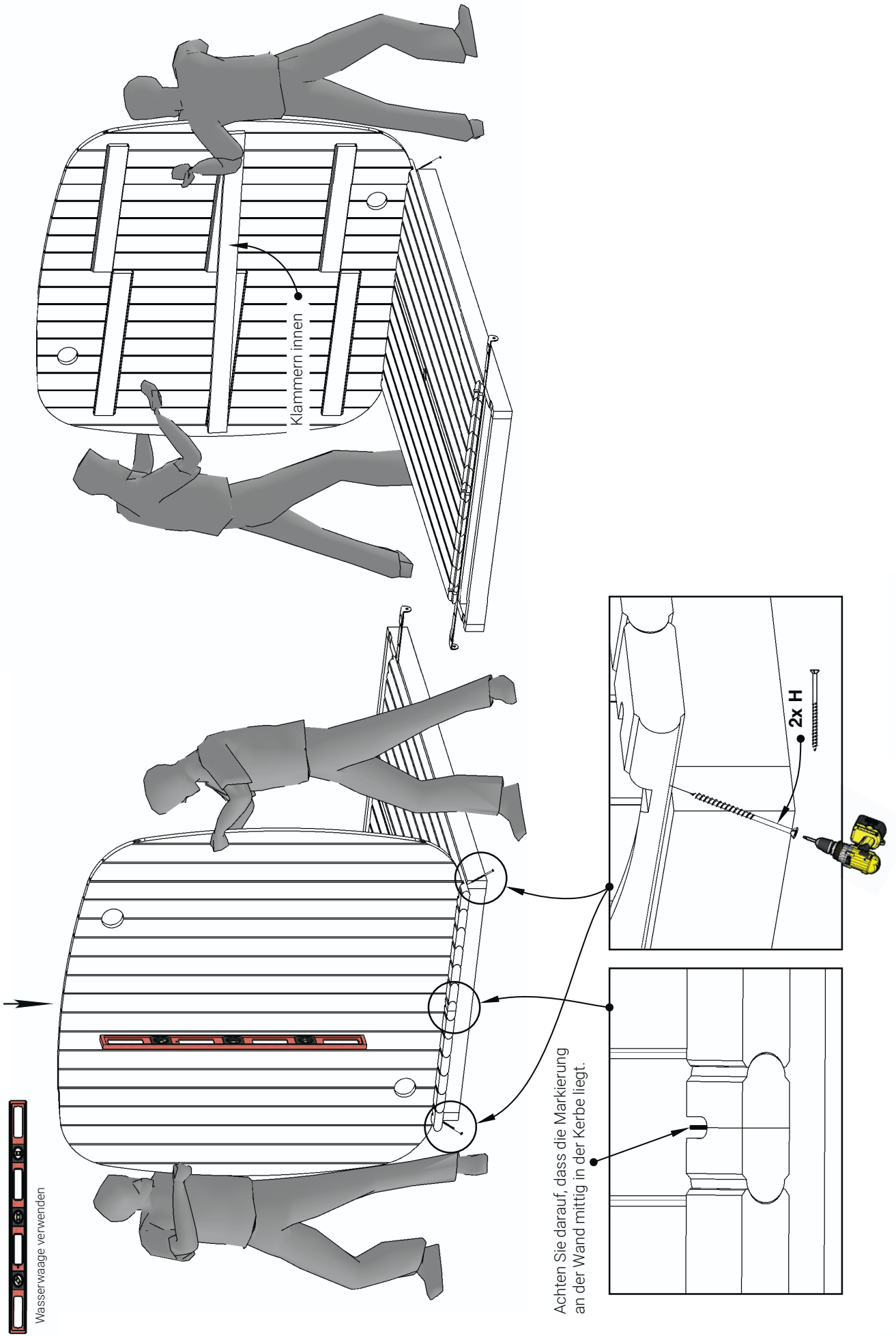

Wasserwaage verwenden

Klammern innen

Achten Sie darauf, dass die Markierung an der Wand mittig in der Kerbe liegt.

2x H

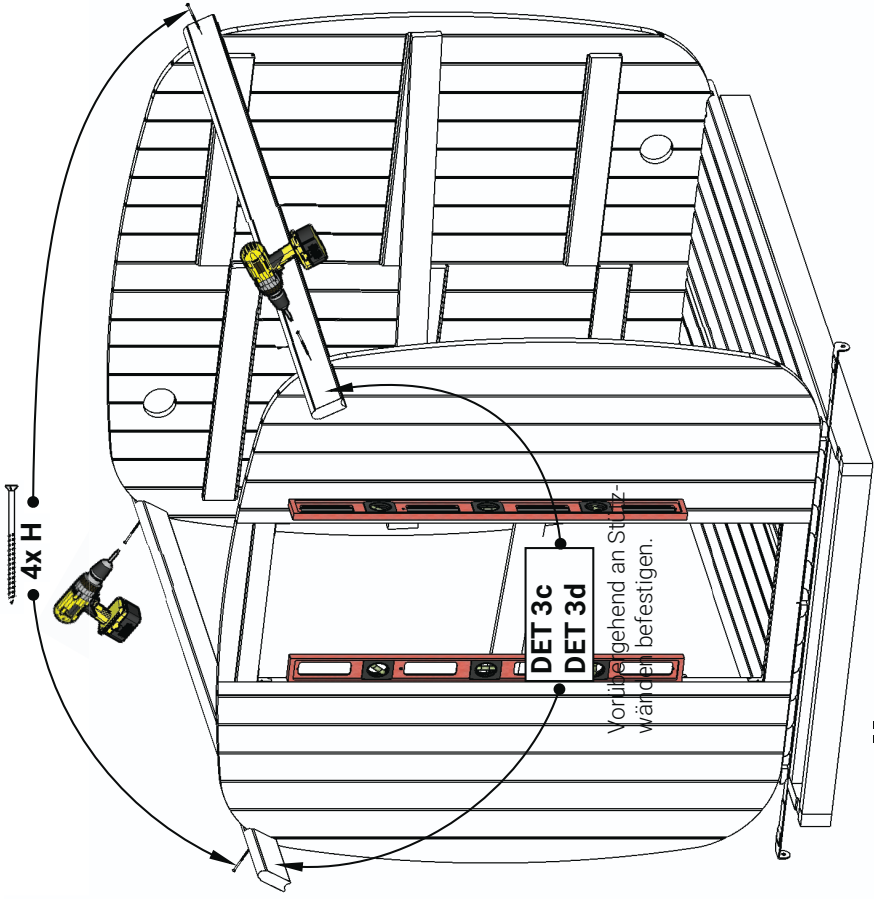

||

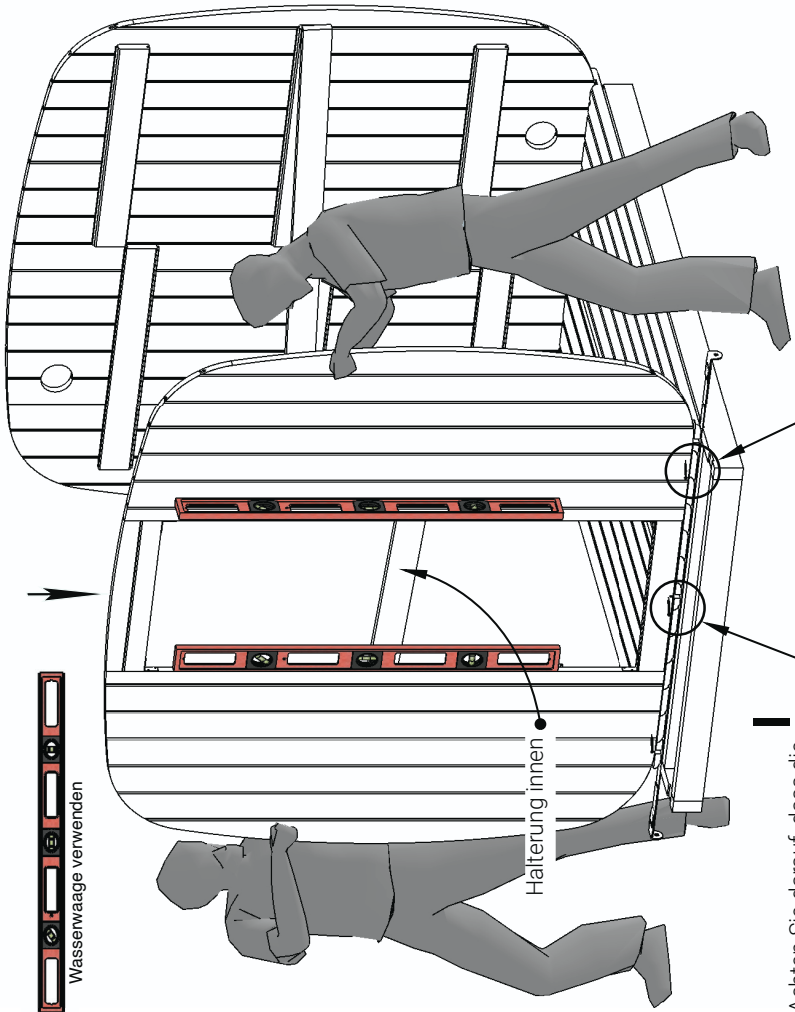

Achten Sie darauf, dass die
Markierung an der Wand mittig
in der Kerbe liegt.

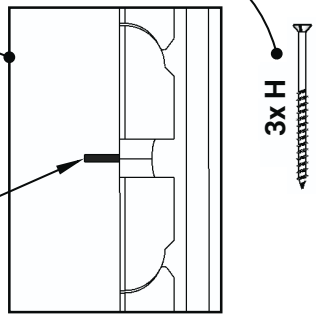
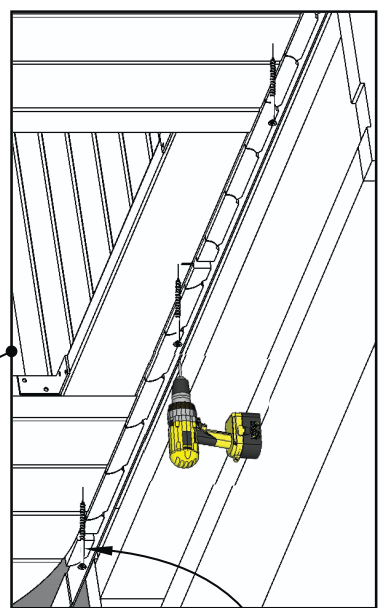

Entfernen Sie DET 3c/d aus ihren temporären Positionen und verwenden Sie sie im nächsten Schritt.

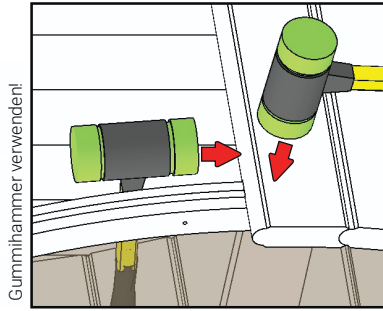

Platzieren Sie DET A1, bevor Sie mit der Installation der Wandstäbe beginnen.

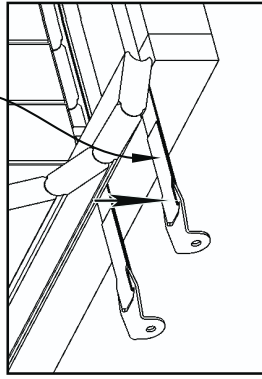

Bereiten Sie die Details wie auf Seite 1 beschrieben vor.

Siehe nächste Seite.

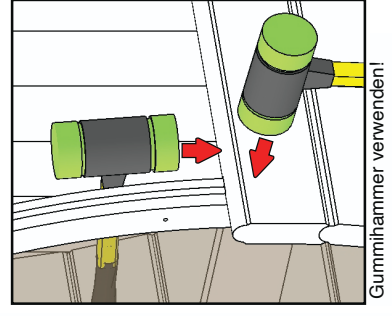
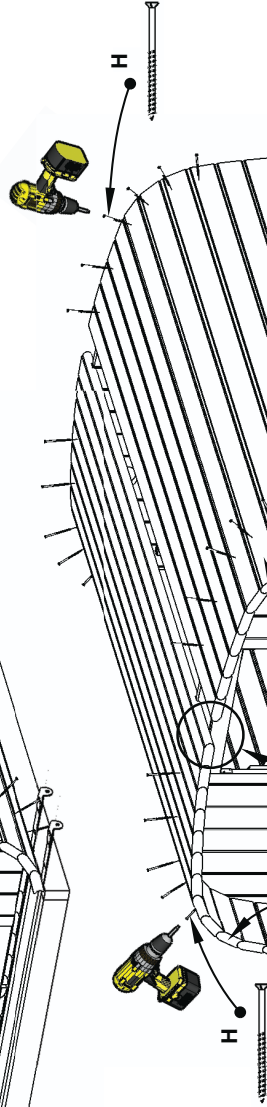
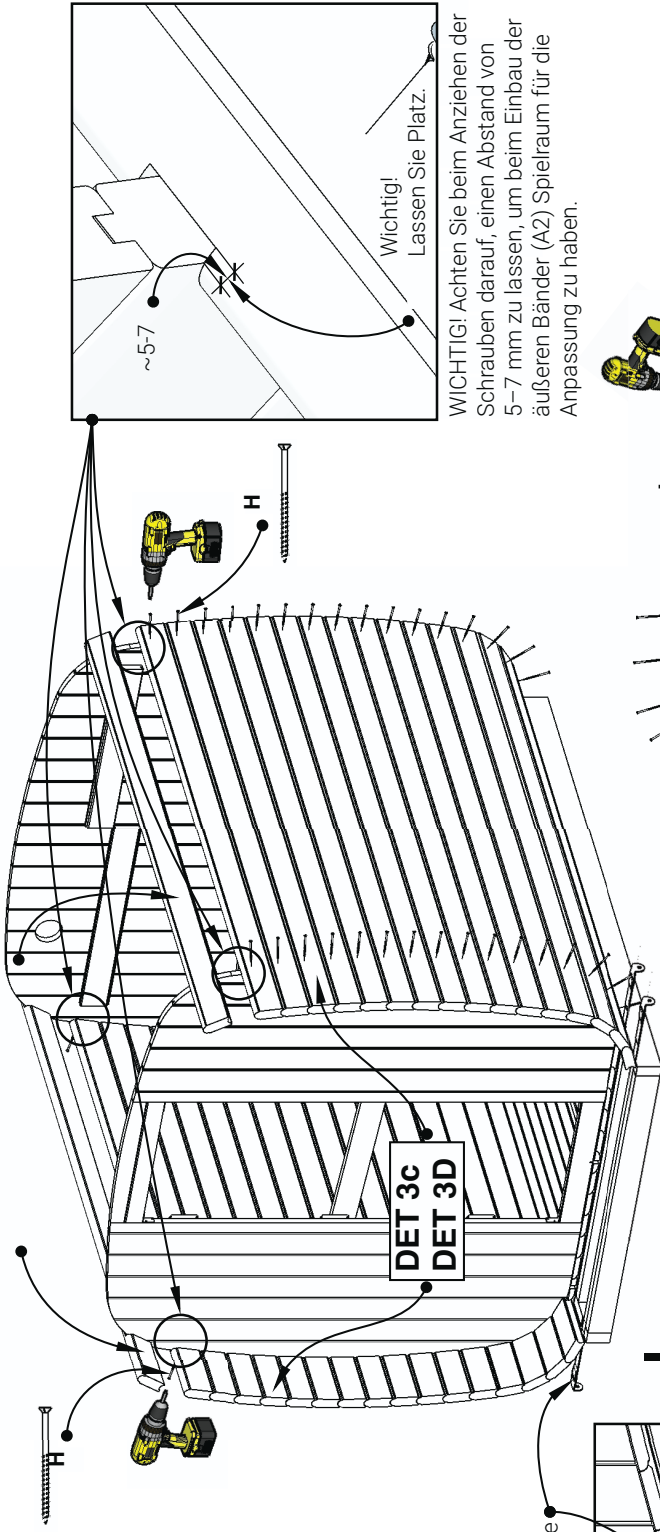
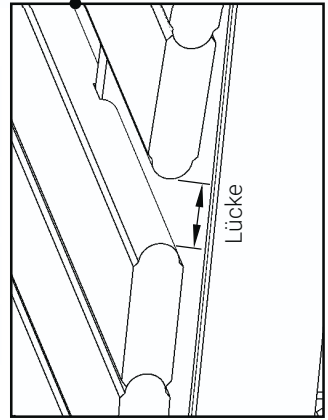

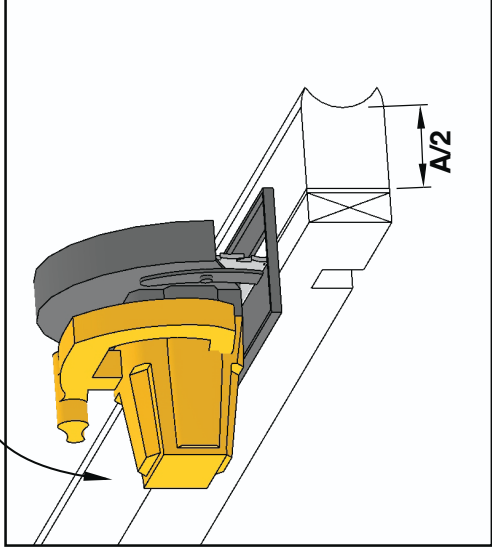
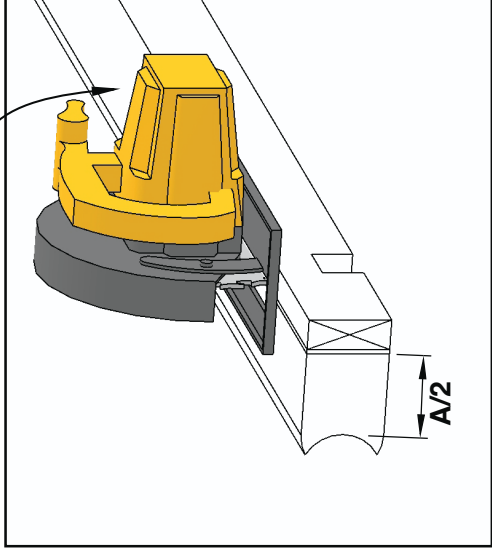
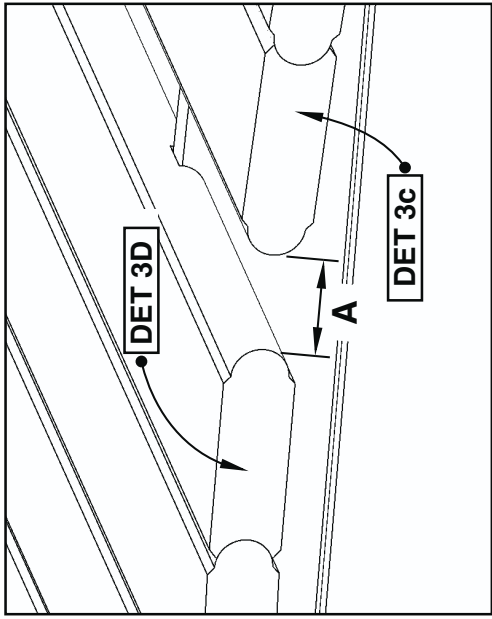

KCH

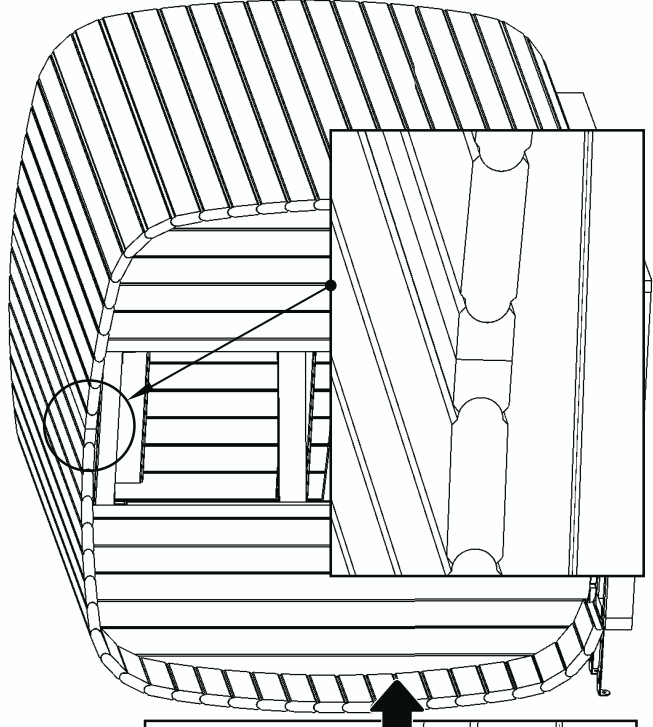
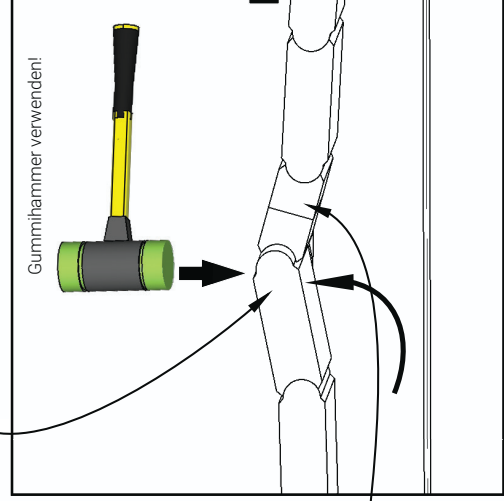
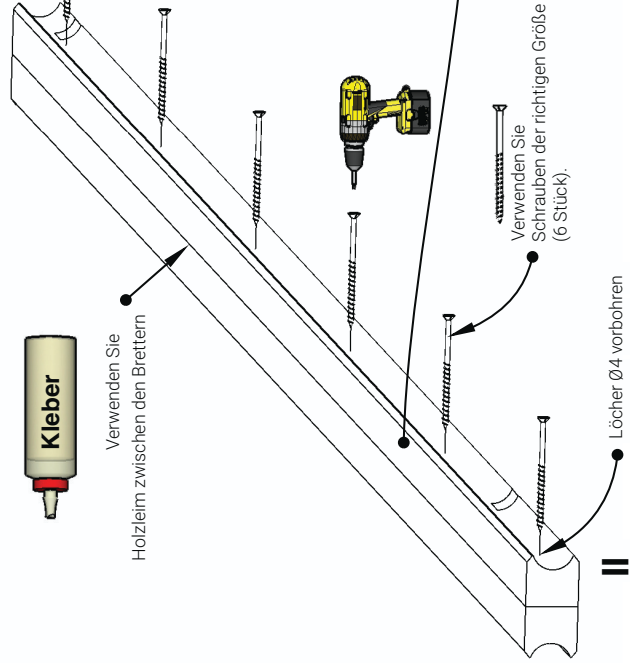

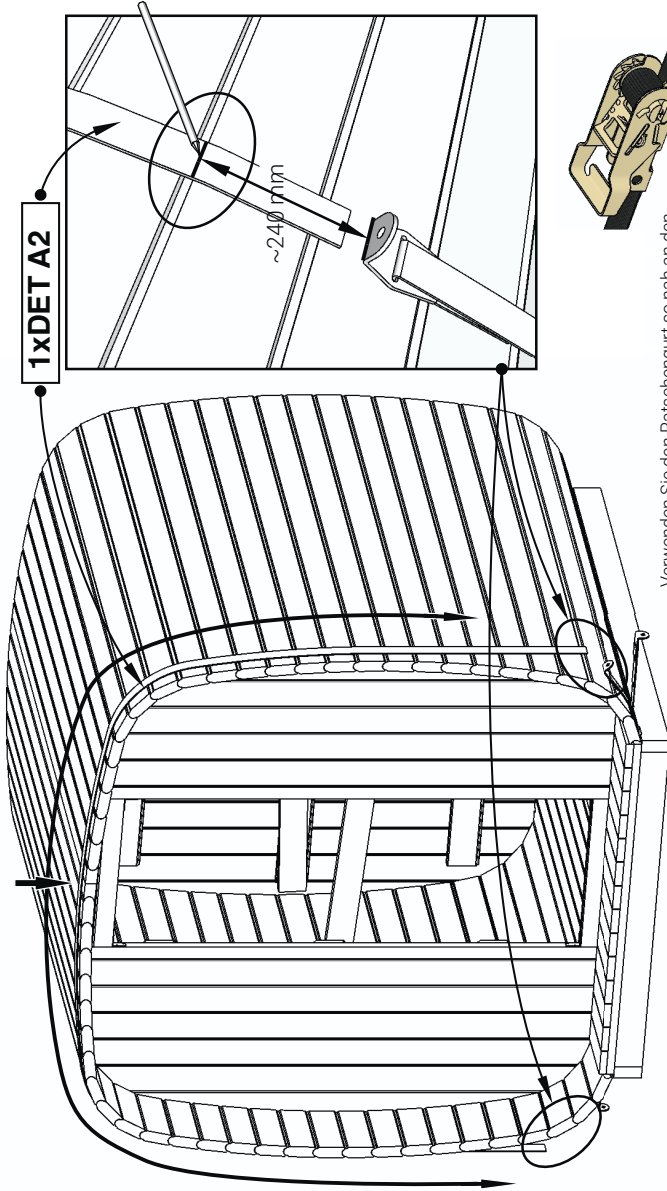
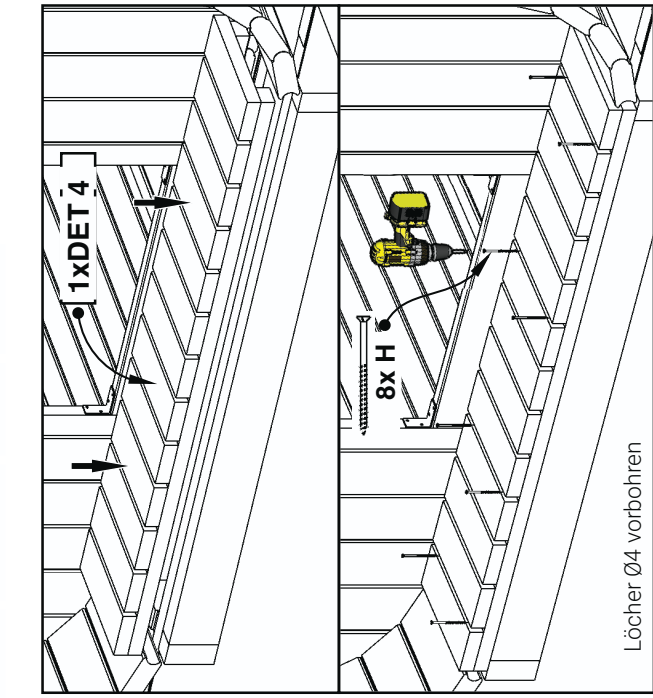

Verwenden Sie den Ratschengurt so nah an den Enden, dass Sie die Schrauben entfernen können.

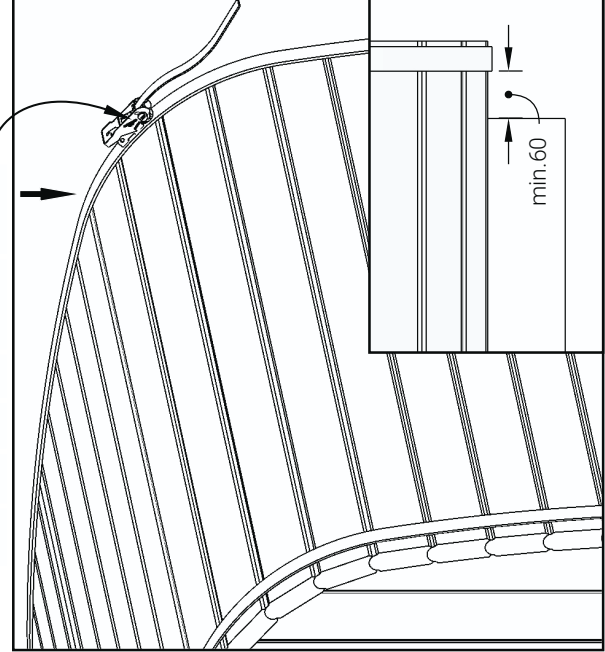

Muttern noch nicht ganz fest anziehen!

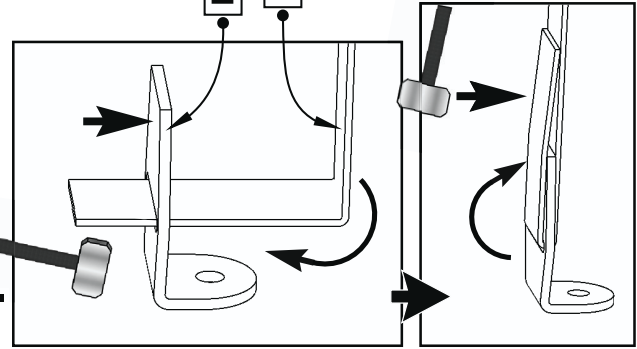
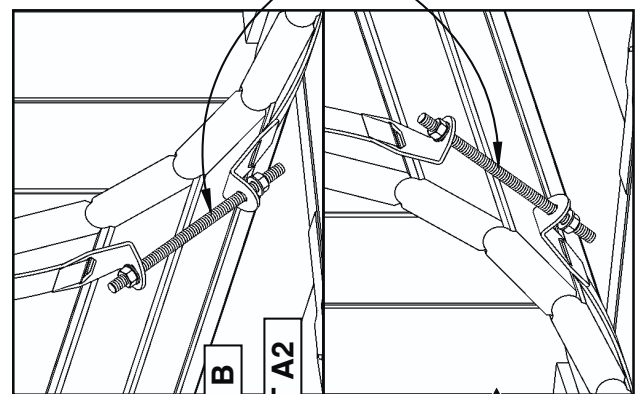
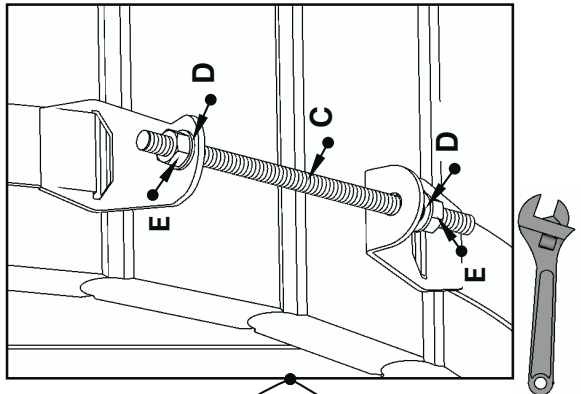

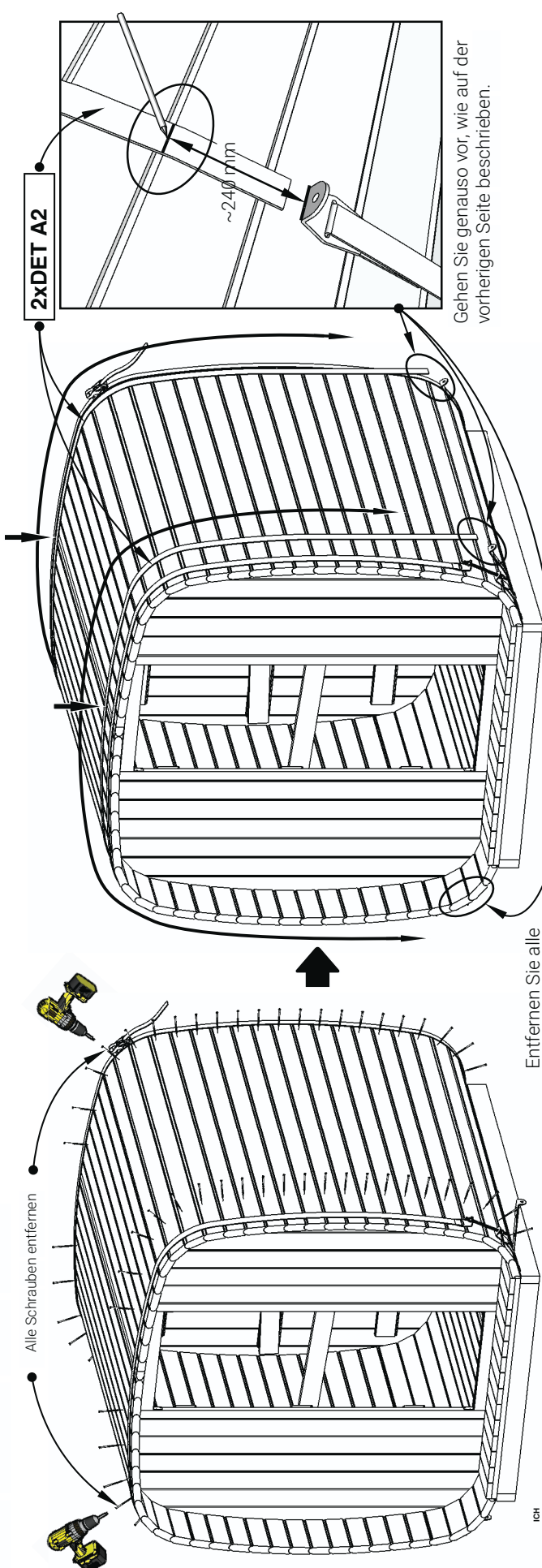

Alle Schrauben entfernen

2xDET A2

~240 mm

Gehen Sie genauso vor, wie auf der vorherigen Seite beschrieben.

Entfernen Sie alle Klammern.

Nun alle M \ddot{u} ttern fest anziehen!
Ratschengurt entfernen!

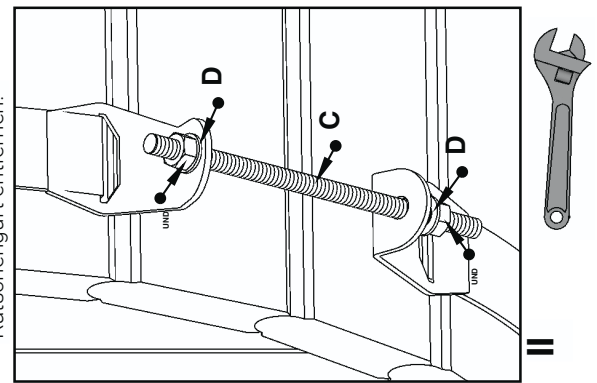
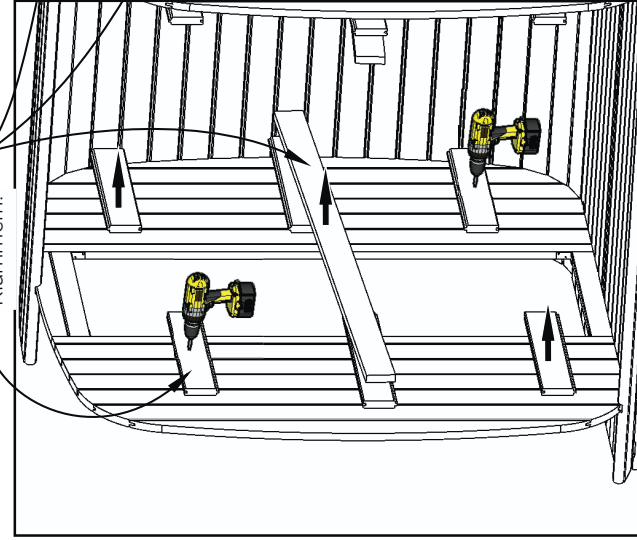
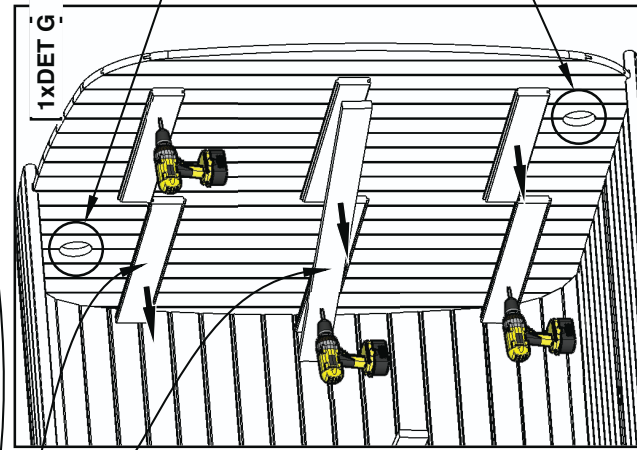
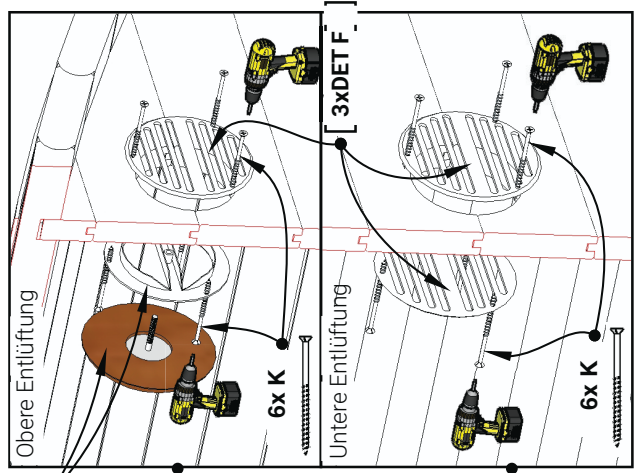

III

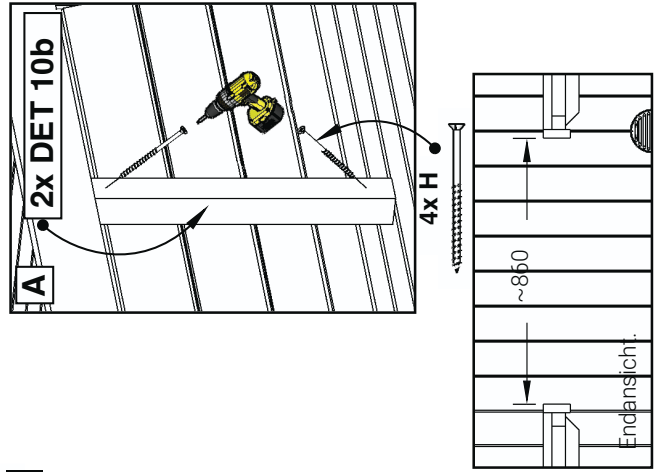
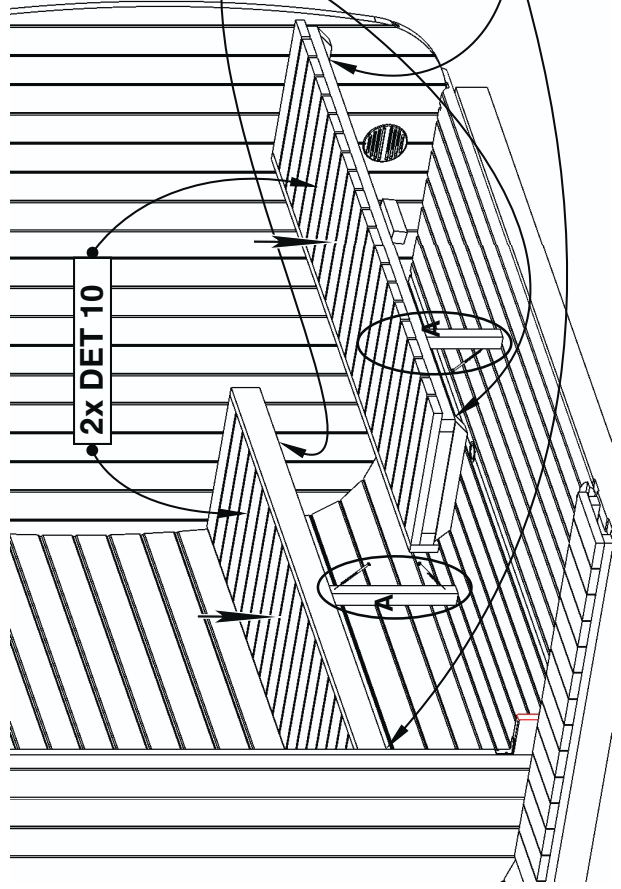
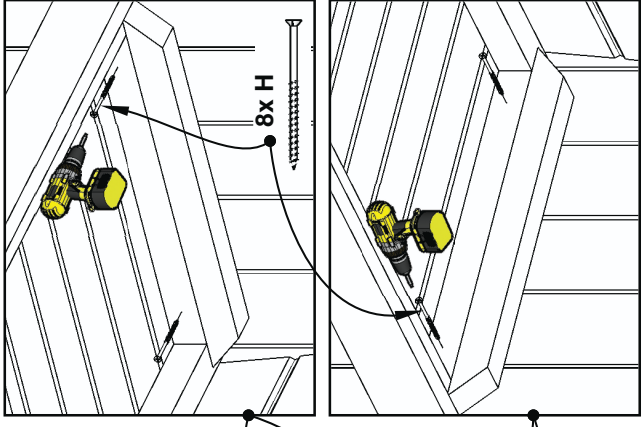
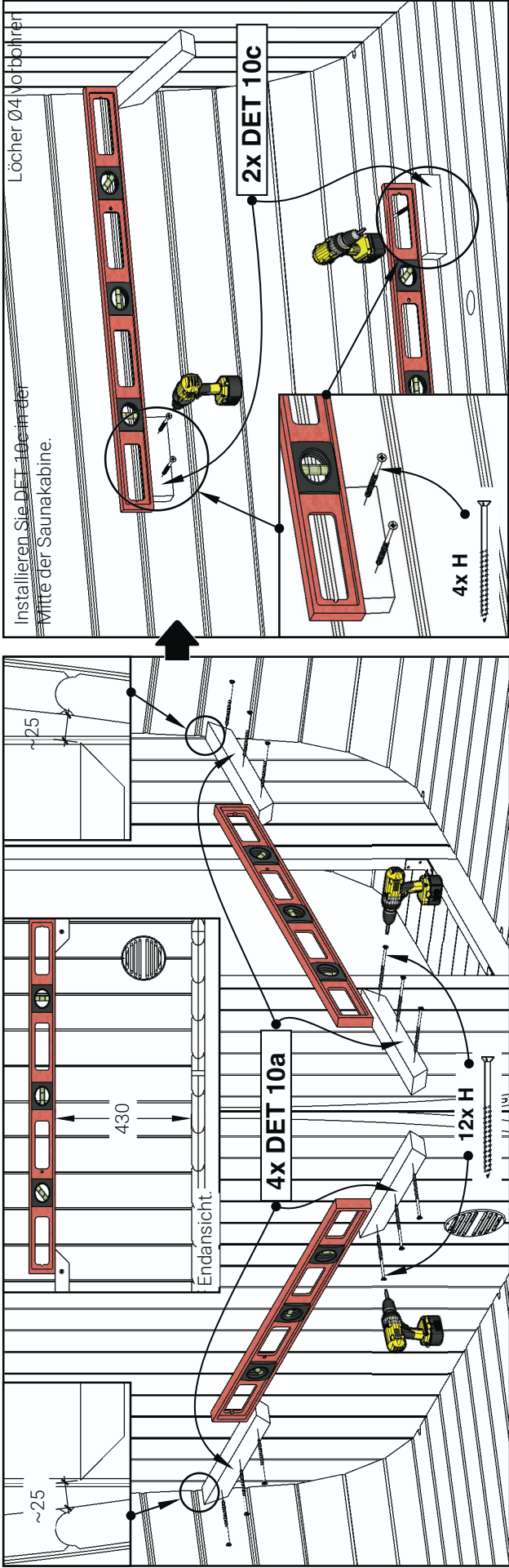

II

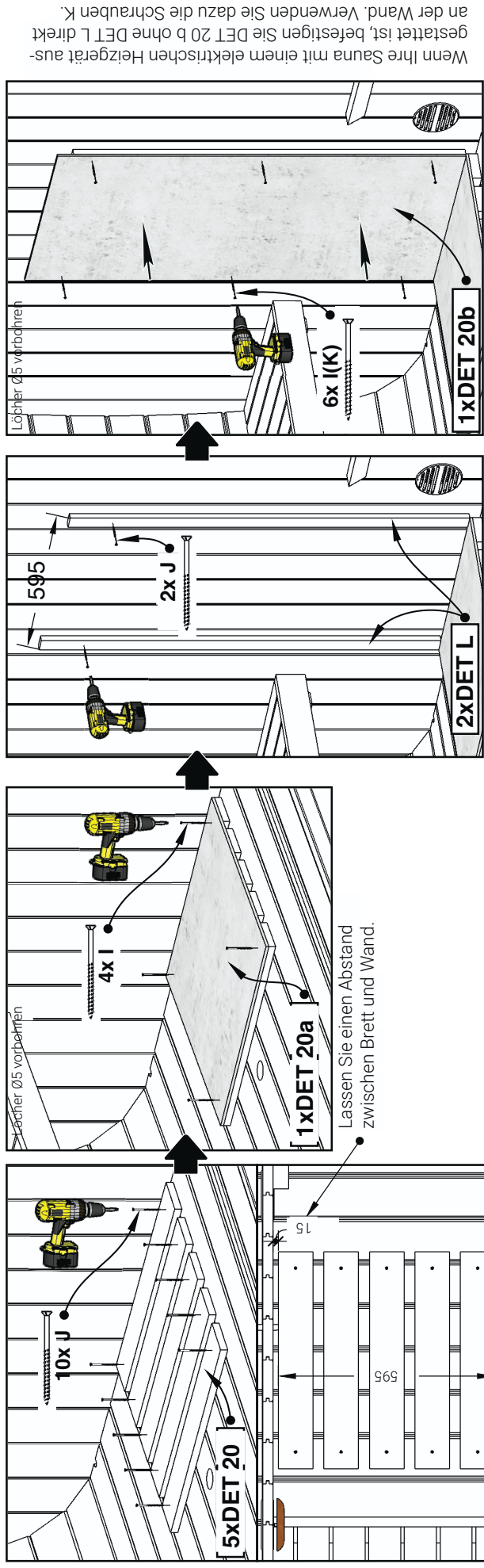

Wenn Ihre Sauna mit einem elektrischen Heizgerät ausgestattet ist, befestigen Sie DET 20 b ohne DET L direkt an der Wand. Verwenden Sie dazu die Schrauben K.

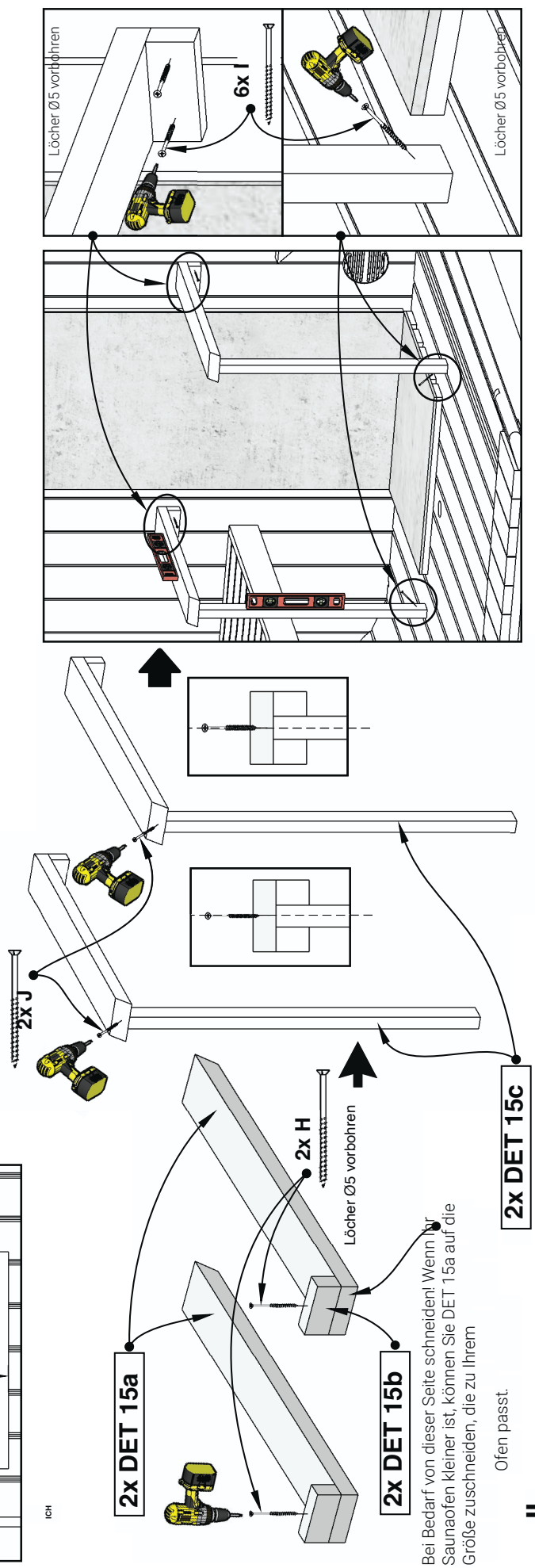

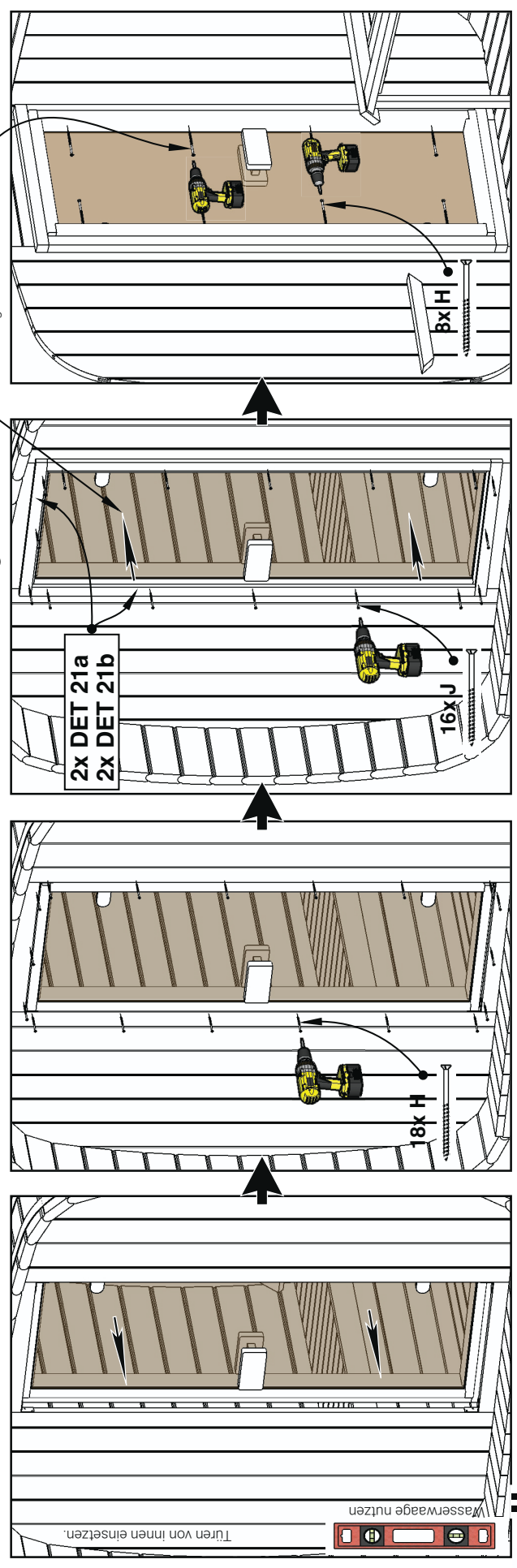
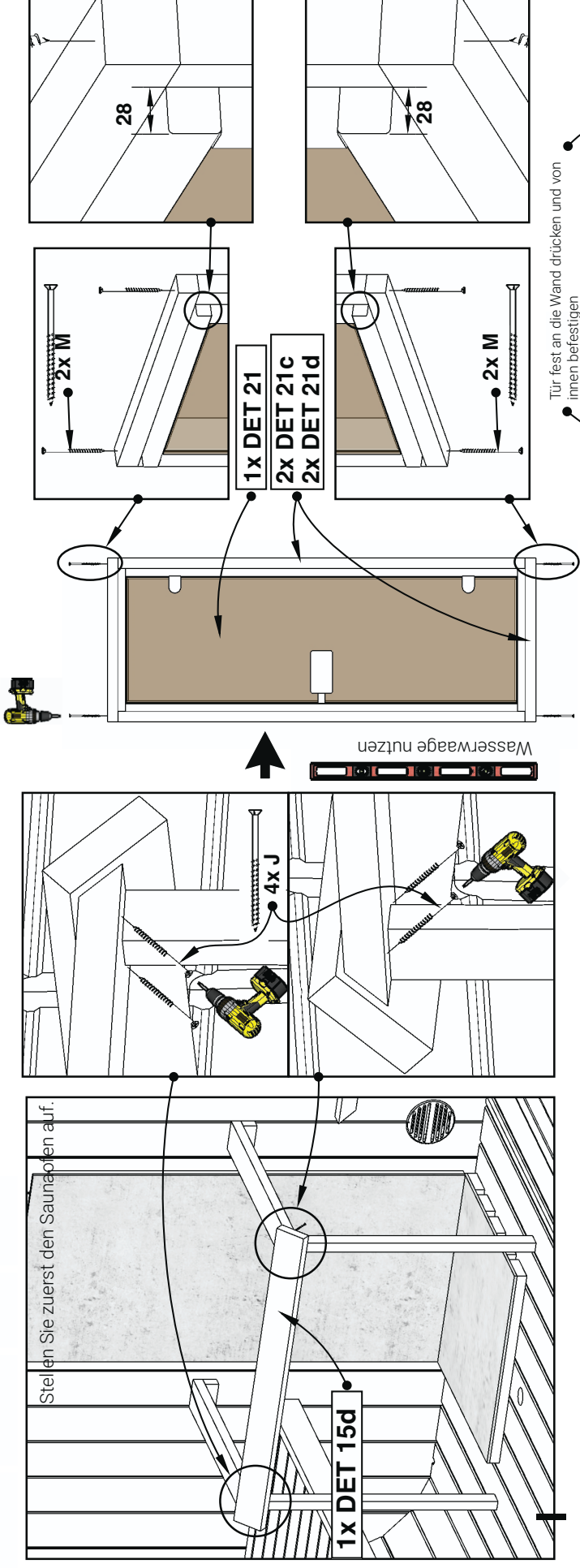

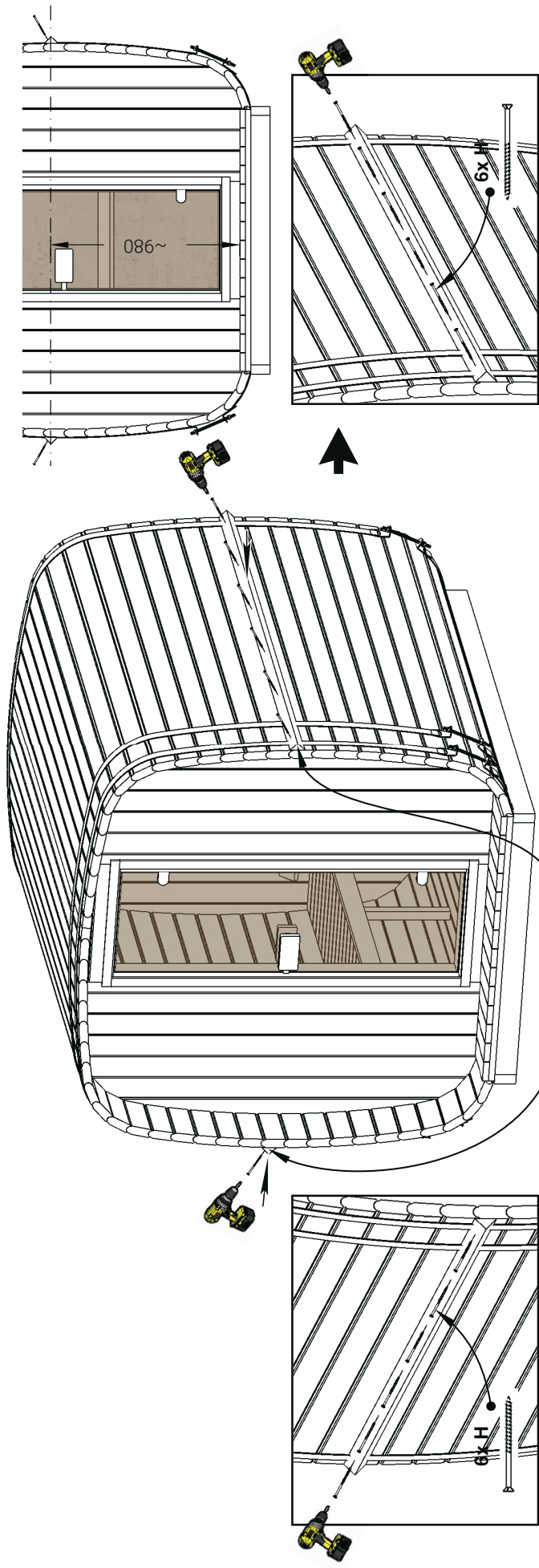

ICH

Achtung! Vor dem Verlegen der Dachschindeln Unterspannbahnen anbringen. Lesen Sie die Installationsanleitung für Unterlagelitz auf den zusätzlichen Seiten.

Achtung! Beachten Sie die im Paket enthaltene Installationsanleitung für Schindeln.

DET N

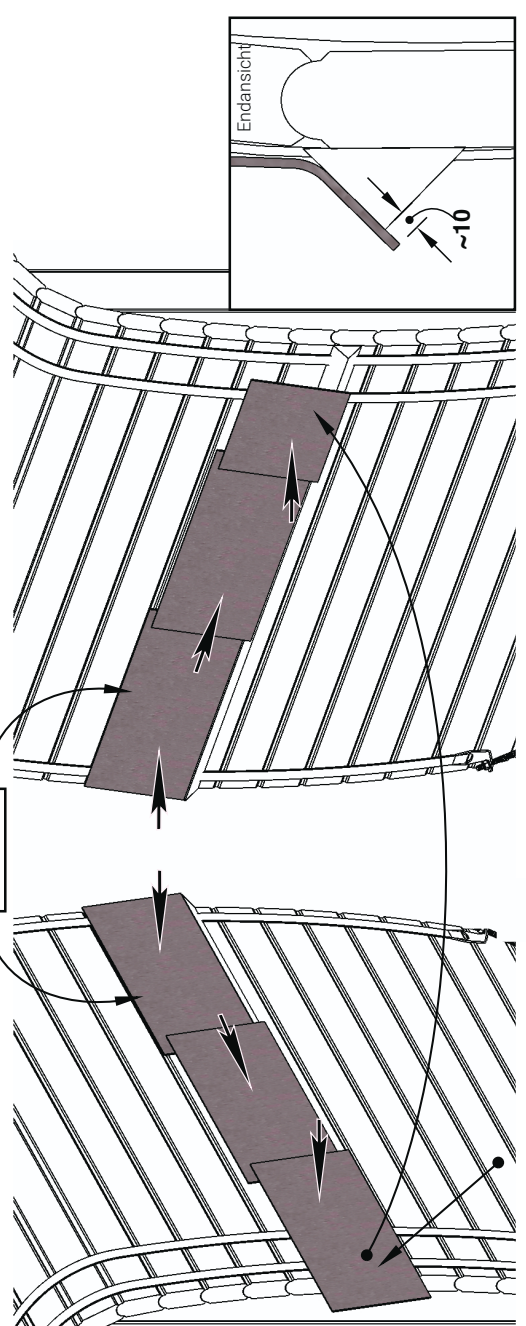

Den Rest abschneiden und auf der gegenüberliegenden Seite verwenden.



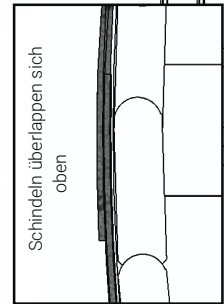

Achtung! Beachten Sie die im Paket enthaltene Installationsanleitung für Schindeln.

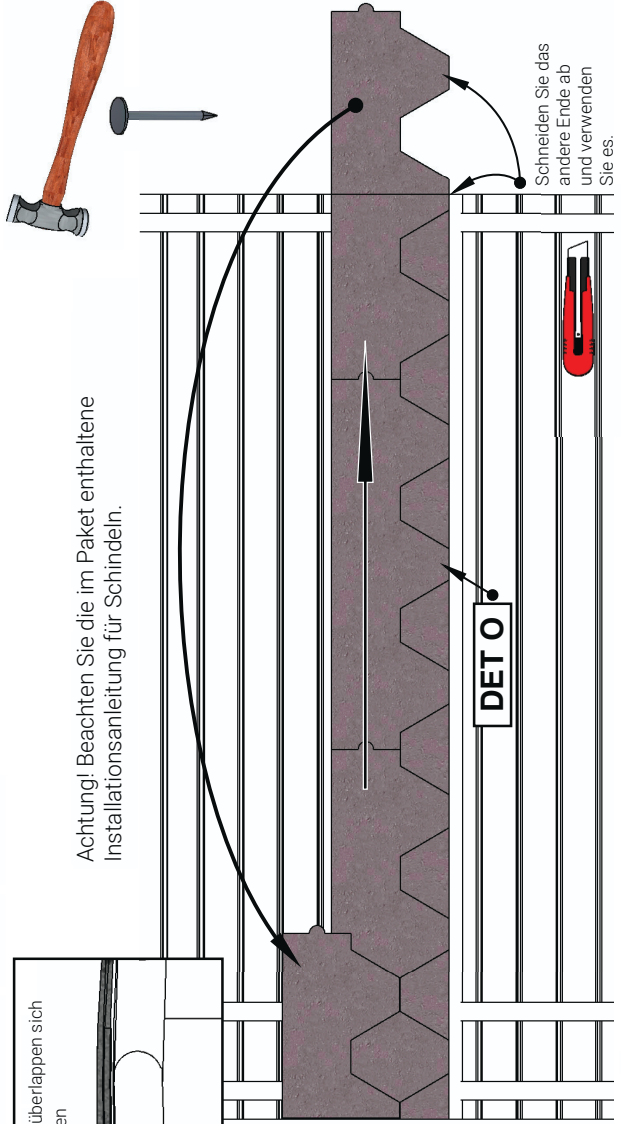

Achtung! Beachten Sie die im Paket enthaltene Installationsanleitung für Schindeln.

Brechen Sie DET N in 3 Teile.

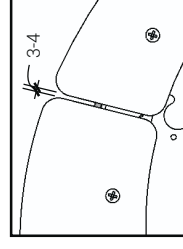
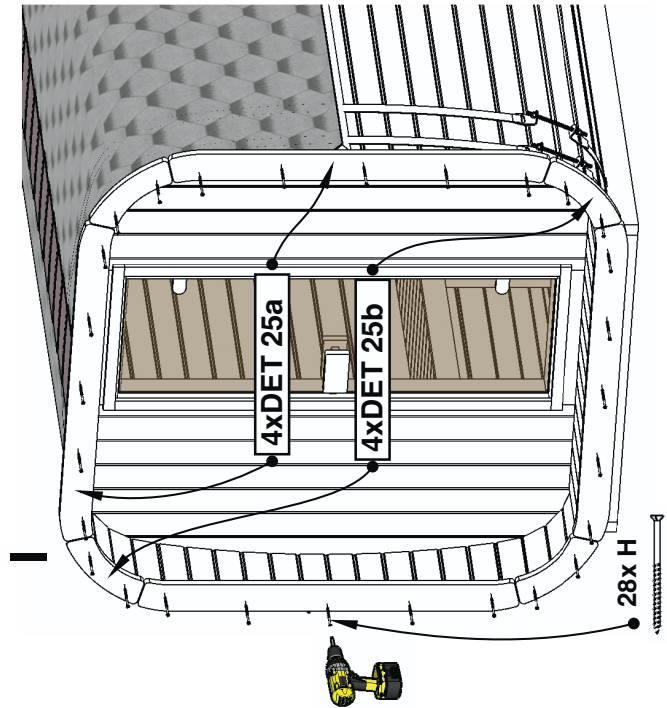
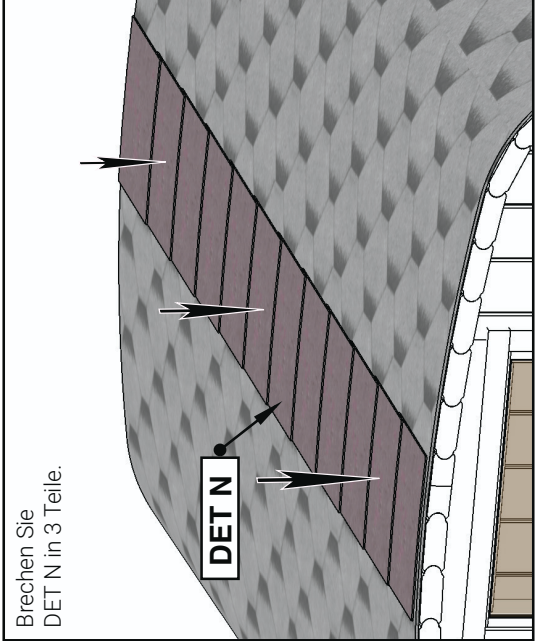

Lassen Sie einen kleinen Abstand zwischen den Brettern.

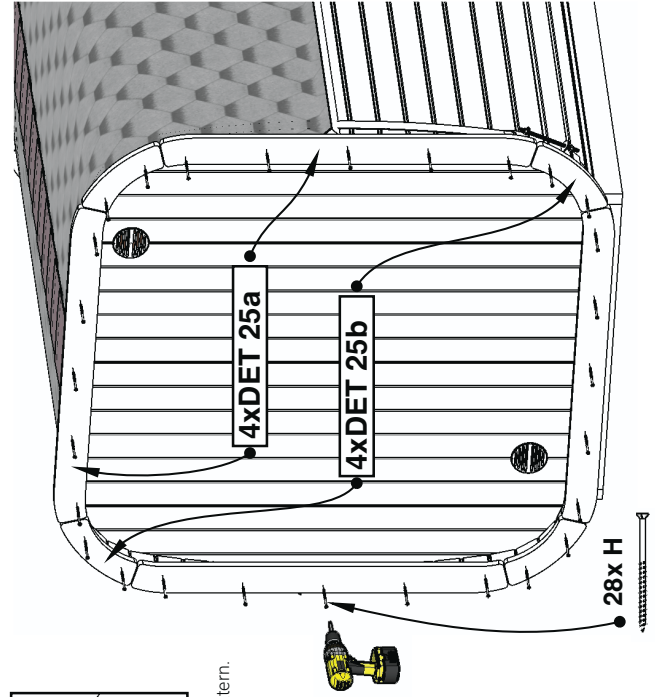

Installationsanleitung für Dachbahnen

Achtung! Beachten Sie die im Paket enthaltene Installationsanleitung für die Unterlage.

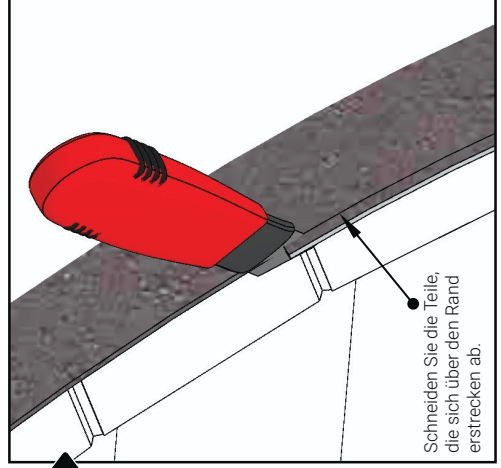
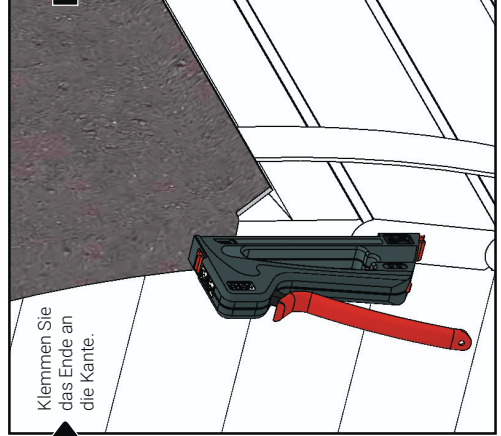
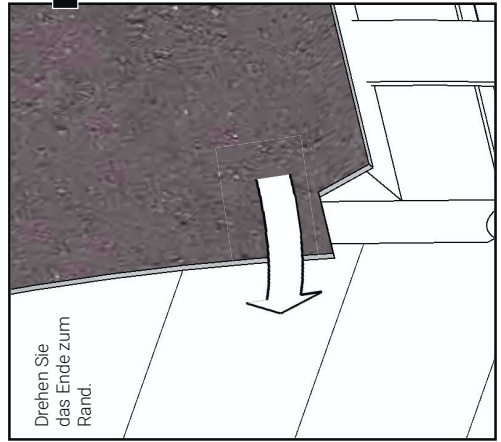
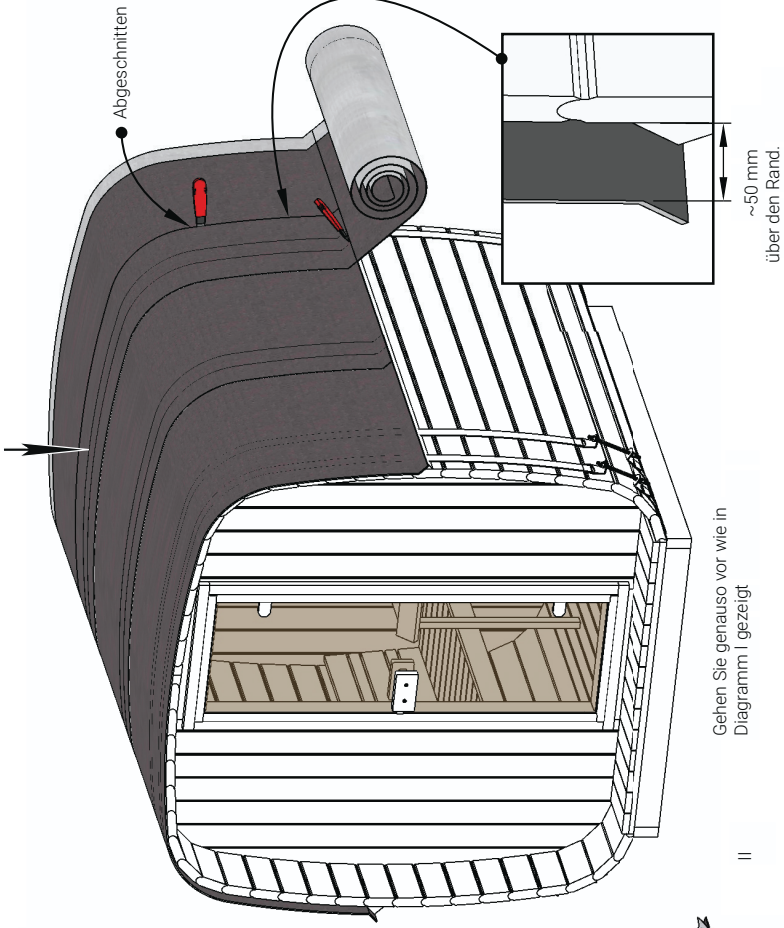
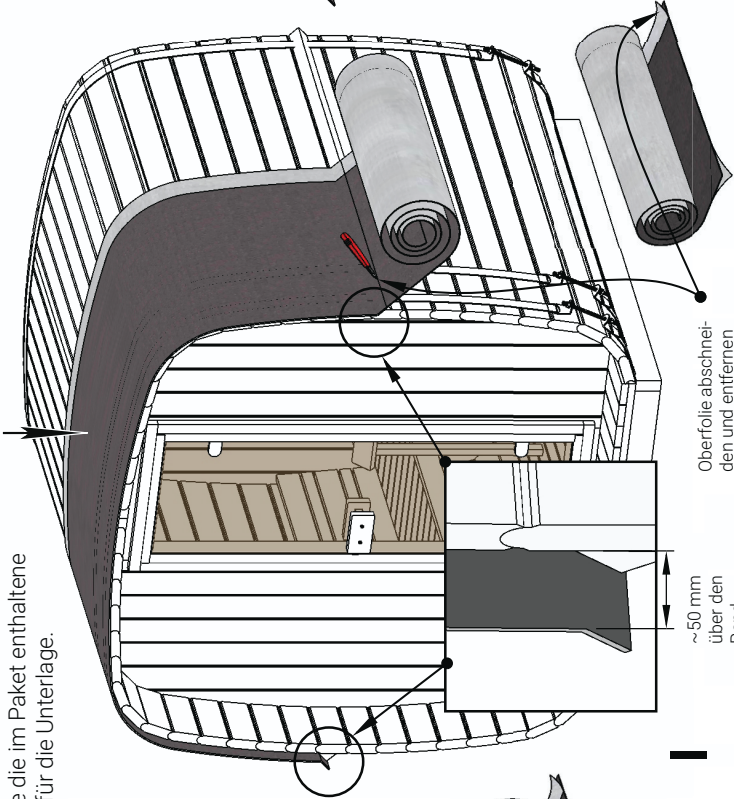
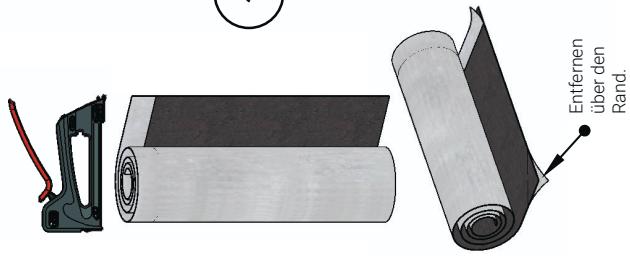

III